



Please note that Cypress is an Infineon Technologies Company.

The document following this cover page is marked as “Cypress” document as this is the company that originally developed the product. Please note that Infineon will continue to offer the product to new and existing customers as part of the Infineon product portfolio.

Continuity of document content

The fact that Infineon offers the following product as part of the Infineon product portfolio does not lead to any changes to this document. Future revisions will occur when appropriate, and any changes will be set out on the document history page.

Continuity of ordering part numbers

Infineon continues to support existing part numbers. Please continue to use the ordering part numbers listed in the datasheet for ordering.

The CY95630H Series is a series of general-purpose, single-chip microcontrollers. In addition to a compact instruction set, the microcontrollers of this series contain a variety of peripheral functions.

Features

- F²MC-8FX CPU core
 - Instruction set optimized for controllers
 - Multiplication and division instructions
 - 16-bit arithmetic operations
 - Bit test branch instructions
 - Bit manipulation instructions, etc.
- Clock
 - Selectable main clock source
 - Main oscillation clock (up to 16.25 MHz, maximum machine clock frequency: 8.125 MHz)
 - External clock (up to 32.5 MHz, maximum machine clock frequency: 16.25 MHz)
 - Main CR clock (4 MHz ±2%)
 - Main CR PLL clock
 - The main CR PLL clock frequency becomes 8 MHz ±2% when the PLL multiplication rate is 2.
 - The main CR PLL clock frequency becomes 10 MHz ±2% when the PLL multiplication rate is 2.5.
 - The main CR PLL clock frequency becomes 12 MHz ±2% when the PLL multiplication rate is 3.
 - The main CR PLL clock frequency becomes 16 MHz ±2% when the PLL multiplication rate is 4.
 - Selectable subclock source
 - Suboscillation clock (32.768 kHz)
 - External clock (32.768 kHz)
 - Sub-CR clock (Typ: 100 kHz, Min: 50 kHz, Max: 150 kHz)
- Timer
 - 8/16-bit composite timer × 2 channels
 - 8/16-bit PPG × 3 channels
 - 16-bit PPG timer × 1 channel (can work independently or together with the multi-pulse generator)
 - 16-bit reload timer × 1 channel (can work independently or together with the multi-pulse generator)
 - Time-base timer × 1 channel
 - Watch prescaler × 1 channel
- UART/SIO × 1 channel
 - Full duplex double buffer
 - Capable of clock asynchronous (UART) serial data transfer and clock synchronous (SIO) serial data transfer
- I²C bus interface × 1 channel
 - Built-in wake-up function
- Multi-pulse generator (MPG) (for DC motor control) × 1 channel
 - 16-bit reload timer × 1 channel
 - 16-bit PPG timer × 1 channel
 - Waveform sequencer (including a 16-bit timer equipped with a buffer and a compare clear function)
- LIN-UART
 - Full duplex double buffer
- Capable of clock asynchronous serial data transfer and clock synchronous serial data transfer
- External interrupt × 10 channels
 - Interrupt by edge detection (rising edge, falling edge, and both edges can be selected)
 - Can be used to wake up the device from different low power consumption (standby) modes
- 8/10-bit A/D converter × 8 channels
 - 8-bit or 10-bit resolution can be selected.
- Low power consumption (standby) modes
 - There are four standby modes as follows:
 - Stop mode
 - Sleep mode
 - Watch mode
 - Time-base timer mode
 - In standby mode, two further options can be selected: normal standby mode and deep standby mode.
- I/O port
 - CY95F632H/F633H/F634H/F636H (number of I/O ports: 28)
 - General-purpose I/O ports (CMOS I/O): 25
 - General-purpose I/O ports (N-ch open drain): 3
 - CY95F632K/F633K/F634K/F636K (number of I/O ports: 29)
 - General-purpose I/O ports (CMOS I/O): 25
 - General-purpose I/O ports (N-ch open drain): 4
- On-chip debug
 - 1-wire serial control
 - Serial writing supported (asynchronous mode)
- Hardware/software watchdog timer
 - Built-in hardware watchdog timer
 - Built-in software watchdog timer
- Power-on reset
 - A power-on reset is generated when the power is switched on.
- Low-voltage detection reset circuit (only available on CY95F632K/F633K/F634K/F636K)
 - Built-in low-voltage detection function (The combination of detection voltage and release voltage can be selected from four options.)
- Comparator
- Clock supervisor counter
 - Built-in clock supervisor counter
- Dual operation Flash memory
 - The program/erase operation and the read operation can be executed in different banks (upper bank/lower bank) simultaneously.
- Flash memory security function
 - Protects the content of the Flash memory.

Contents

Features	1	15. I/O Ports	30
1. Product Line-up	3	15.1 Port 0.....	31
2. Packages And Corresponding Products	5	15.2 Port 1.....	39
3. Differences Among Products And Notes On Product Selection	5	15.3 Port 6.....	46
4. Pin Assignment	6	15.4 Port F.....	51
5. Pin Functions	8	15.5 Port G.....	53
6. I/O Circuit Type	12	16. Interrupt Source Table	56
7. Handling Precautions	14	17. Pin States In Each Mode	57
7.1 Precautions for Product Design.....	14	18. Electrical Characteristics	61
7.2 Precautions for Package Mounting	15	18.1 Absolute Maximum Ratings.....	61
7.3 Precautions for Use Environment.....	17	18.2 Recommended Operating Conditions	63
8. Notes On Device Handling	17	18.3 DC Characteristics	64
9. Pin Connection	18	18.4 AC Characteristics.....	67
10. Block Diagram	19	18.5 A/D Converter.....	85
11. CPU Core	20	18.6 Flash Memory Program/Erase Characteristics..	89
12. Memory Space	21	19. Sample Characteristics	90
13. Areas For Specific Applications	23	20. Mask Options	97
14. I/O Map	24	21. Ordering Information	97
		22. Package Dimension	98
		23. Major Changes In This Edition	101
		Document History Page	101
		Sales, Solutions, and Legal Information	102

1. Product Line-up

Part number	CY95F632H	CY95F633H	CY95F634H	CY95F636H	CY95F632K	CY95F633K	CY95F634K	CY95F636K
Parameter								
Type	Flash memory product							
Clock supervisor counter	It supervises the main clock oscillation and the subclock oscillation.							
Flash memory capacity	8 Kbyte	12 Kbyte	20 Kbyte	36 Kbyte	8 Kbyte	12 Kbyte	20 Kbyte	36 Kbyte
RAM capacity	256 bytes	512 bytes	1024 bytes	1024 bytes	256 bytes	512 bytes	1024 bytes	1024 bytes
Power-on reset	Yes							
Low-voltage detection reset	No				Yes			
Reset input	Dedicated				Selected through software			
CPU functions	<ul style="list-style-type: none"> • Number of basic instructions : 136 • Instruction bit length : 8 bits • Instruction length : 1 to 3 bytes • Data bit length : 1, 8 and 16 bits • Minimum instruction execution time : 61.5 ns (machine clock frequency = 16.25 MHz) • Interrupt processing time : 0.6 μs (machine clock frequency = 16.25 MHz) 							
General-purpose I/O	<ul style="list-style-type: none"> • I/O port : 28 • CMOS I/O : 25 • N-ch open drain : 3 				<ul style="list-style-type: none"> • I/O port : 29 • CMOS I/O : 25 • N-ch open drain : 4 			
Time-base timer	Interval time: 0.256 ms to 8.3 s (external clock frequency = 4 MHz)							
Hardware/software watchdog timer	<ul style="list-style-type: none"> • Reset generation cycle Main oscillation clock at 10 MHz: 105 ms (Min) • The sub-CR clock can be used as the source clock of the software watchdog timer. 							
Wild register	It can be used to replace 3 bytes of data.							
LIN-UART	<ul style="list-style-type: none"> • A wide range of communication speed can be selected by a dedicated reload timer. • It has a full duplex double buffer. • Both clock synchronous serial data transfer and clock asynchronous serial data transfer are enabled. • The LIN function can be used as a LIN master or a LIN slave. 							
8/10-bit A/D converter	8 channels							
	8-bit or 10-bit resolution can be selected.							
8/16-bit composite timer	2 channels							
	<ul style="list-style-type: none"> • The timer can be configured as an “8-bit timer × 2 channels” or a “16-bit timer × 1 channel”. • It has the following functions: interval timer function, PWC function, PWM function and input capture function. • Count clock: it can be selected from internal clocks (seven types) and external clocks. • It can output square wave. 							

Part number	CY95F632H	CY95F633H	CY95F634H	CY95F636H	CY95F632K	CY95F633K	CY95F634K	CY95F636K
Parameter								
External interrupt	10 channels <ul style="list-style-type: none"> Interrupt by edge detection (The rising edge, falling edge, and both edges can be selected.) It can be used to wake up the device from different standby modes. 							
On-chip debug	<ul style="list-style-type: none"> 1-wire serial control It supports serial writing (asynchronous mode). 							
UART/SIO	1 channel <ul style="list-style-type: none"> Data transfer with UART/SIO is enabled. It has a full duplex double buffer, variable data length (5/6/7/8 bits), an internal baud rate generator and an error detection function. It uses the NRZ type transfer format. LSB-first data transfer and MSB-first data transfer are available to use. Both clock asynchronous (UART) serial data transfer and clock synchronous (SIO) serial data transfer are enabled. 							
I ² C bus interface	1 channel <ul style="list-style-type: none"> Master/slave transmission and reception It has the following functions: bus error function, arbitration function, transfer direction detection function, wake-up function, and functions of generating and detecting repeated START conditions. 							
8/16-bit PPG	3 channels <ul style="list-style-type: none"> Each channel can be used as an “8-bit timer × 2 channels” or a “16-bit timer × 1 channel”. The counter operating clock can be selected from eight clock sources. 							
16-bit PPG timer	1 channel <ul style="list-style-type: none"> PWM mode and one-shot mode are available to use. The counter operating clock can be selected from eight clock sources. It supports external trigger start. It can work independently or together with the multi-pulse generator. 							
16-bit reload timer	1 channel <ul style="list-style-type: none"> Two clock modes and two counter operating modes are available to use. It can output square wave. Count clock: it can be selected from internal clocks (seven types) and external clocks. Two counter operating modes: reload mode and one-shot mode It can work independently or together with the multi-pulse generator. 							
Multi-pulse generator (for DC motor control)	<ul style="list-style-type: none"> 16-bit PPG timer: 1 channel 16-bit reload timer operations: toggle output, one-shot output Event counter: 1 channel Waveform sequencer (including a 16-bit timer equipped with a buffer and a compare clear function) 							
Watch prescaler	Eight different time intervals can be selected.							
Comparator	1 channel							

Part number	CY95F632H	CY95F633H	CY95F634H	CY95F636H	CY95F632K	CY95F633K	CY95F634K	CY95F636K								
Parameter																
Flash memory	<ul style="list-style-type: none"> It supports automatic programming (Embedded Algorithm), and program/erase/erase-suspend/erase-resume commands. It has a flag indicating the completion of the operation of Embedded Algorithm. Flash security feature for protecting the content of the Flash memory <table border="1"> <tr> <td>Number of program/erase cycles</td> <td>1000</td> <td>10000</td> <td>100000</td> </tr> <tr> <td>Data retention time</td> <td>20 years</td> <td>10 years</td> <td>5 years</td> </tr> </table>								Number of program/erase cycles	1000	10000	100000	Data retention time	20 years	10 years	5 years
Number of program/erase cycles	1000	10000	100000													
Data retention time	20 years	10 years	5 years													
Standby mode	<p>There are four standby modes as follows:</p> <ul style="list-style-type: none"> Stop mode Sleep mode Watch mode Time-base timer mode <p>In standby mode, two further options can be selected: normal standby mode and deep standby mode.</p>															
Package	LQB032 PDS032 WNP032															

2. Packages And Corresponding Products

Part number	CY95F632H	CY95F633H	CY95F634H	CY95F636H	CY95F632K	CY95F633K	CY95F634K	CY95F636K
Package								
LQB032	O	O	O	O	O	O	O	O
PDS032	O	O	O	O	O	O	O	O
WNP032	O	O	O	O	O	O	O	O

O: Available

3. Differences Among Products And Notes On Product Selection

- Current consumption
When using the on-chip debug function, take account of the current consumption of Flash memory program/erase. For details of current consumption, see “Electrical Characteristics”.
- Package
For details of information on each package, see “Packages And Corresponding Products” and “Package Dimension”.
- Operating voltage
The operating voltage varies, depending on whether the on-chip debug function is used or not. For details of operating voltage, see “Electrical Characteristics”.
- On-chip debug function

The on-chip debug function requires that V_{cc}, V_{ss} and one serial wire be connected to an evaluation tool. For details of the connection method, refer to “CHAPTER 25 EXAMPLE OF SERIAL PROGRAMMING CONNECTION” in “New 8FX CY95630H Series Hardware Manual”.

4. Pin Assignment

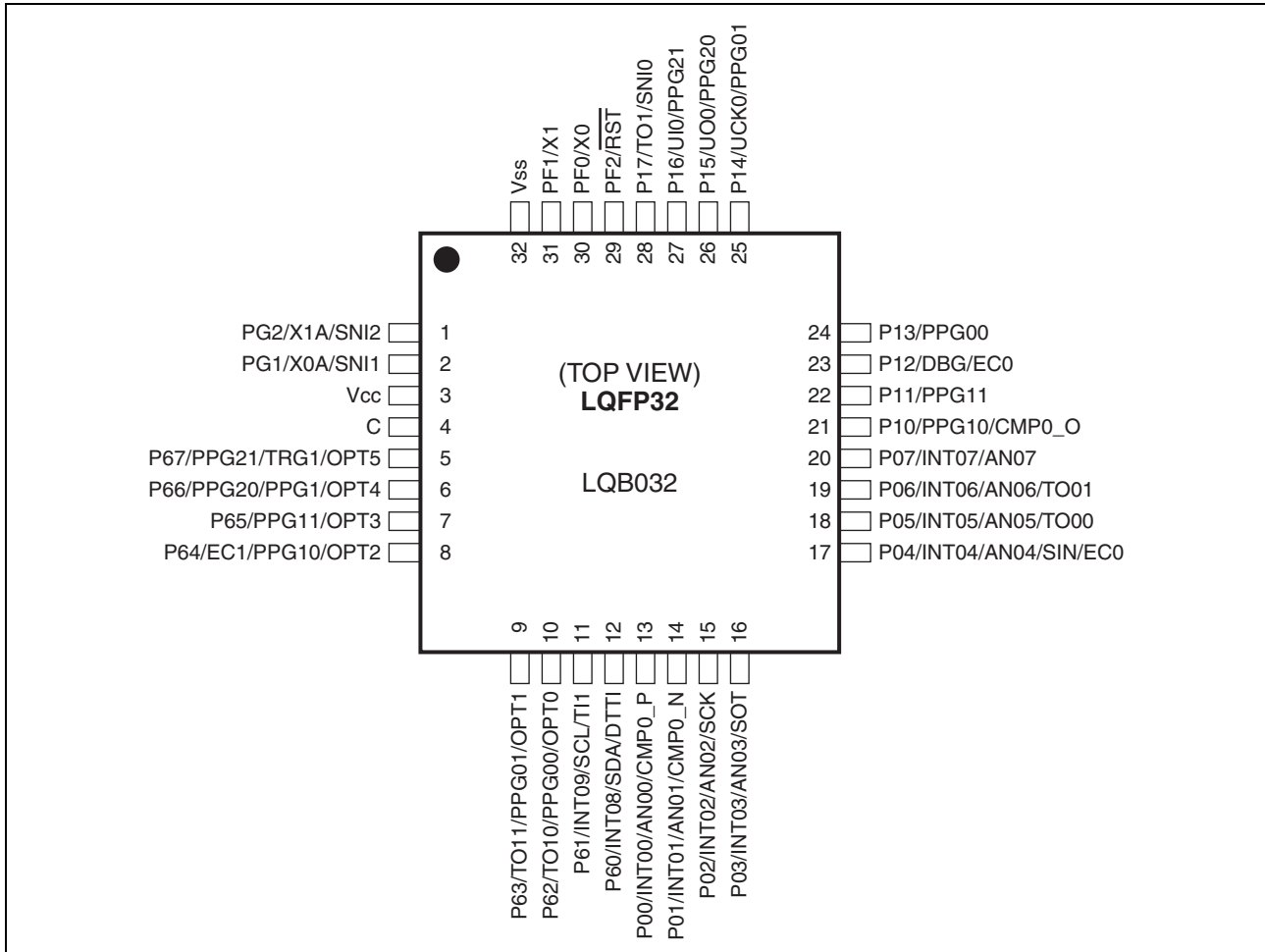

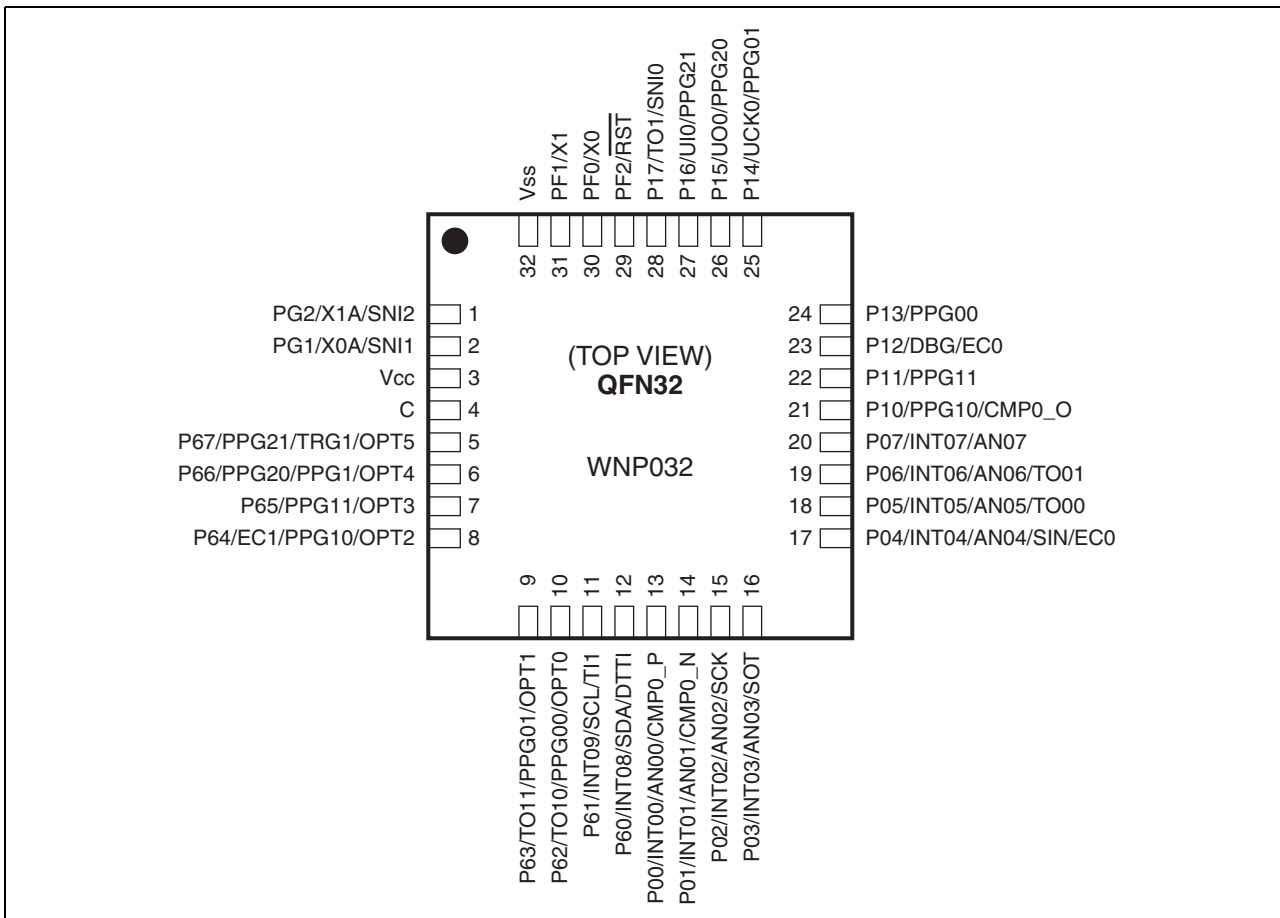
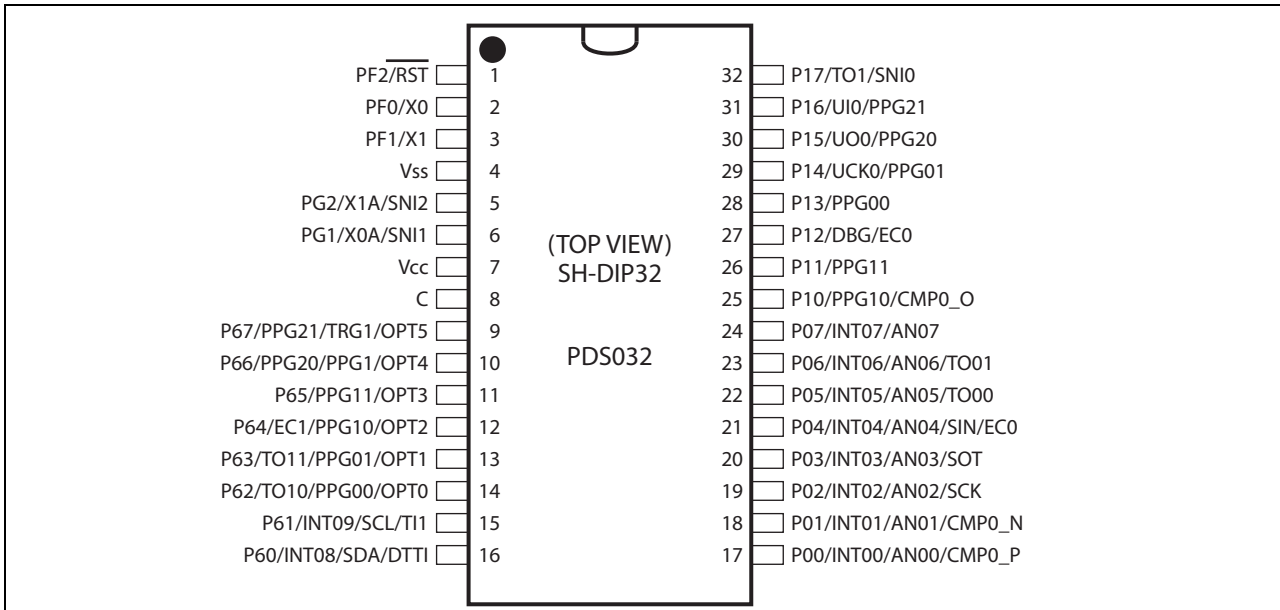

5. Pin Functions

Pin no.		Pin name	I/O circuit type*4	Function	I/O type			
LQFP32*1, QFN32*2	SH-DIP32*3				Input	Output	OD*5	PU*6
1	5	PG2	C	General-purpose I/O port	Hysteresis	CMOS	—	0
		X1A		Subclock I/O oscillation pin				
		SNI2		Trigger input pin for the position detection function of the MPG waveform sequencer				
2	6	PG1	C	General-purpose I/O port	Hysteresis	CMOS	—	0
		X0A		Subclock input oscillation pin				
		SNI1		Trigger input pin for the position detection function of the MPG waveform sequencer				
3	7	Vcc	—	Power supply pin	—	—	—	—
4	8	C	—	Decoupling capacitor connection pin	—	—	—	—
5	9	P67	D	General-purpose I/O port High-current pin	Hysteresis	CMOS	—	0
		PPG21		8/16-bit PPG ch. 2 output pin				
		TRG1		16-bit PPG timer ch. 1 trigger input pin				
		OPT5		MPG waveform sequencer output pin				
6	10	P66	D	General-purpose I/O port High-current pin	Hysteresis	CMOS	—	0
		PPG20		8/16-bit PPG ch. 2 output pin				
		PPG1		16-bit PPG timer ch. 1 output pin				
		OPT4		MPG waveform sequencer output pin				
7	11	P65	D	General-purpose I/O port High-current pin	Hysteresis	CMOS	—	0
		PPG11		8/16-bit PPG ch. 1 output pin				
		OPT3		MPG waveform sequencer output pin				
8	12	P64	D	General-purpose I/O port High-current pin	Hysteresis	CMOS	—	0
		EC1		8/16-bit composite timer ch. 1 clock input pin				
		PPG10		8/16-bit PPG ch. 1 output pin				
		OPT2		MPG waveform sequencer output pin				

Pin no.		Pin name	I/O circuit type*4	Function	I/O type			
LQFP32*1, QFN32*2	SH-DIP32*3				Input	Output	OD*5	PU*6
9	13	P63	D	General-purpose I/O port High-current pin	Hysteresis	CMOS	—	O
		TO11		8/16-bit composite timer ch. 1 output pin				
		PPG01		8/16-bit PPG ch. 0 output pin				
		OPT1		MPG waveform sequencer output pin				
10	14	P62	D	General-purpose I/O port High-current pin	Hysteresis	CMOS	—	O
		TO10		8/16-bit composite timer ch. 1 output pin				
		PPG00		8/16-bit PPG ch. 0 output pin				
		OPT0		MPG waveform sequencer output pin				
11	15	P61	I	General-purpose I/O port	CMOS	CMOS	O	—
		INT09		External interrupt input pin				
		SCL		I ² C bus interface ch. 0 clock I/O pin				
		TI1		16-bit reload timer ch. 1 input pin				
12	16	P60	I	General-purpose I/O port	CMOS	CMOS	O	—
		INT08		External interrupt input pin				
		SDA		I ² C bus interface ch. 0 data I/O pin				
		DTTI		MPG waveform sequencer input pin				
13	17	P00	E	General-purpose I/O port	Hysteresis/ analog	CMOS	—	O
		INT00		External interrupt input pin				
		AN00		8/10-bit A/D converter analog input pin				
		CMP0_P		Comparator non-inverting analog input (positive input) pin				
14	18	P01	E	General-purpose I/O port	Hysteresis/ analog	CMOS	—	O
		INT01		External interrupt input pin				
		AN01		8/10-bit A/D converter analog input pin				
		CMP0_N		Comparator inverting analog input (negative input) pin				

Pin no.		Pin name	I/O circuit type*4	Function	I/O type			
LQFP32*1, QFN32*2	SH-DIP32*3				Input	Output	OD*5	PU*6
15	19	P02	E	General-purpose I/O port	Hysteresis/ analog	CMOS	—	O
		INT02		External interrupt input pin				
		AN02		8/10-bit A/D converter analog input pin				
		SCK		LIN-UART clock I/O pin				
16	20	P03	E	General-purpose I/O port	Hysteresis/ analog	CMOS	—	O
		INT03		External interrupt input pin				
		AN03		8/10-bit A/D converter analog input pin				
		SOT		LIN-UART data output pin				
17	21	P04	F	General-purpose I/O port	CMOS/ analog	CMOS	—	O
		INT04		External interrupt input pin				
		AN04		8/10-bit A/D converter analog input pin				
		SIN		LIN-UART data input pin				
		EC0		8/16-bit composite timer ch. 0 clock input pin				
18	22	P05	E	General-purpose I/O port	Hysteresis/ analog	CMOS	—	O
		INT05		External interrupt input pin				
		AN05		8/10-bit A/D converter analog input pin				
		TO00		8/16-bit composite timer ch. 0 output pin				
19	23	P06	E	General-purpose I/O port	Hysteresis/ analog	CMOS	—	O
		INT06		External interrupt input pin				
		AN06		8/10-bit A/D converter analog input pin				
		TO01		8/16-bit composite timer ch. 0 output pin				
20	24	P07	E	General-purpose I/O port	Hysteresis/ analog	CMOS	—	O
		INT07		External interrupt input pin				
		AN07		8/10-bit A/D converter analog input pin				
21	25	P10	G	General-purpose I/O port	Hysteresis	CMOS	—	O
		PPG10		8/16-bit PPG ch. 1 output pin				
		CMP0_O		Comparator digital output pin				

Pin no.		Pin name	I/O circuit type*4	Function	I/O type			
LQFP32*1, QFN32*2	SH-DIP32*3				Input	Output	OD*5	PU*6
22	26	P11	G	General-purpose I/O port	Hysteresis	CMOS	—	O
		PPG11		8/16-bit PPG ch. 1 output pin				
23	27	P12	H	General-purpose I/O port	Hysteresis	CMOS	O	—
		DBG		DBG input pin				
		EC0		8/16-bit composite timer ch. 0 clock input pin				
24	28	P13	G	General-purpose I/O port	Hysteresis	CMOS	—	O
		PPG00		8/16-bit PPG ch. 0 output pin				
25	29	P14	G	General-purpose I/O port	Hysteresis	CMOS	—	O
		UCK0		UART/SIO ch. 0 clock I/O pin				
		PPG01		8/16-bit PPG ch. 0 output pin				
26	30	P15	G	General-purpose I/O port	Hysteresis	CMOS	—	O
		UO0		UART/SIO ch. 0 data output pin				
		PPG20		8/16-bit PPG ch. 2 output pin				
27	31	P16	J	General-purpose I/O port	CMOS	CMOS	—	O
		UI0		UART/SIO ch. 0 data input pin				
		PPG21		8/16-bit PPG ch. 2 output pin				
28	32	P17	G	General-purpose I/O port	Hysteresis	CMOS	—	O
		TO1		16-bit reload timer ch. 1 output pin				
		SNI0		Trigger input pin for the position detection function of the MPG waveform sequencer				
29	1	PF2	A	General-purpose I/O port	Hysteresis	CMOS	O	—
		$\overline{\text{RST}}$		Reset pin Dedicated reset pin on CY95F632H/F633H/F634H/ F636H				
30	2	PF0	B	General-purpose I/O port	Hysteresis	CMOS	—	—
		X0		Main clock input oscillation pin				
31	3	PF1	B	General-purpose I/O port	Hysteresis	CMOS	—	—
		X1		Main clock I/O oscillation pin				
32	4	V _{SS}	—	Power supply pin (GND)	—	—	—	—

O: Available

*4: For the I/O circuit types, see "I/O Circuit Type".

*5: N-ch open drain

*6: Pull-up

*1: LQB032

*2: WNP032

*3: PDS032

6. I/O Circuit Type

Type	Circuit	Remarks
A		<ul style="list-style-type: none"> • N-ch open drain output • Hysteresis input • Reset output
B		<ul style="list-style-type: none"> • Oscillation circuit • High-speed side Feedback resistance: approx. 1 MΩ • CMOS output • Hysteresis input
C		<ul style="list-style-type: none"> • Oscillation circuit • Low-speed side Feedback resistance: approx. 5 MΩ • CMOS output • Hysteresis input • Pull-up control

Type	Circuit	Remarks
D		<ul style="list-style-type: none"> • CMOS output • Hysteresis input • Pull-up control • High current output
E		<ul style="list-style-type: none"> • CMOS output • Hysteresis input • Pull-up control • Analog input
F		<ul style="list-style-type: none"> • CMOS output • CMOS input • Pull-up control • Analog input
G		<ul style="list-style-type: none"> • CMOS output • Hysteresis input • Pull-up control
H		<ul style="list-style-type: none"> • N-ch open drain output • Hysteresis input

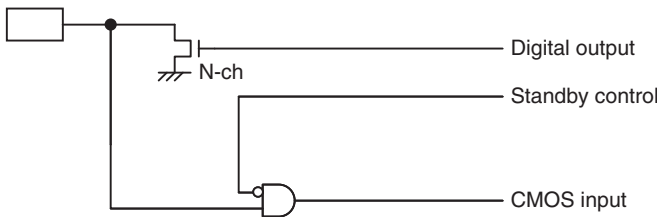
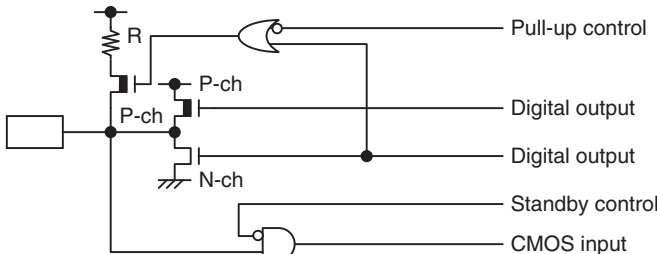
Type	Circuit	Remarks
I		<ul style="list-style-type: none"> • N-ch open drain output • CMOS input
J		<ul style="list-style-type: none"> • CMOS output • CMOS input • Pull-up control

7. Handling Precautions

Any semiconductor devices have inherently a certain rate of failure. The possibility of failure is greatly affected by the conditions in which they are used (circuit conditions, environmental conditions, etc.). This page describes precautions that must be observed to minimize the chance of failure and to obtain higher reliability from your Cypress semiconductor devices.

7.1 Precautions for Product Design

This section describes precautions when designing electronic equipment using semiconductor devices.

• Absolute Maximum Ratings

Semiconductor devices can be permanently damaged by application of stress (voltage, current, temperature, etc.) in excess of certain established limits, called absolute maximum ratings. Do not exceed these ratings.

• Recommended Operating Conditions

Recommended operating conditions are normal operating ranges for the semiconductor device. All the device's electrical characteristics are warranted when operated within these ranges.

Always use semiconductor devices within the recommended operating conditions. Operation outside these ranges may adversely affect reliability and could result in device failure.

No warranty is made with respect to uses, operating conditions, or combinations not represented on the data sheet. Users considering application outside the listed conditions are advised to contact their sales representative beforehand.

• Processing and Protection of Pins

These precautions must be followed when handling the pins which connect semiconductor devices to power supply and input/output functions.

(1) Preventing Over-Voltage and Over-Current Conditions

Exposure to voltage or current levels in excess of maximum ratings at any pin is likely to cause deterioration within the device, and in extreme cases leads to permanent damage of the device. Try to prevent such overvoltage or over-current conditions at the design stage.

(2) Protection of Output Pins

Shorting of output pins to supply pins or other output pins, or connection to large capacitance can cause large current flows. Such conditions if present for extended periods of time can damage the device.

Therefore, avoid this type of connection.

(3) Handling of Unused Input Pins

Unconnected input pins with very high impedance levels can adversely affect stability of operation. Such pins should be connected through an appropriate resistance to a power supply pin or ground pin.

• Latch-up

Semiconductor devices are constructed by the formation of P-type and N-type areas on a substrate. When subjected to abnormally high voltages, internal parasitic PNPN junctions (called thyristor structures) may be formed, causing large current levels in excess of several hundred mA to flow continuously at the power supply pin. This condition is called latch-up.

CAUTION: The occurrence of latch-up not only causes loss of reliability in the semiconductor device, but can cause injury or damage from high heat, smoke or flame. To prevent this from happening, do the following:

- (1) Be sure that voltages applied to pins do not exceed the absolute maximum ratings. This should include attention to abnormal noise, surge levels, etc.
- (2) Be sure that abnormal current flows do not occur during the power-on sequence.

• Observance of Safety Regulations and Standards

Most countries in the world have established standards and regulations regarding safety, protection from electromagnetic interference, etc. Customers are requested to observe applicable regulations and standards in the design of products.

• Fail-Safe Design

Any semiconductor devices have inherently a certain rate of failure. You must protect against injury, damage or loss from such failures by incorporating safety design measures into your facility and equipment such as redundancy, fire protection, and prevention of over-current levels and other abnormal operating conditions.

• Precautions Related to Usage of Devices

Cypress semiconductor devices are intended for use in standard applications (computers, office automation and other office equipment, industrial, communications, and measurement equipment, personal or household devices, etc.).

CAUTION: Customers considering the use of our products in special applications where failure or abnormal operation may directly affect human lives or cause physical injury or property damage, or where extremely high levels of reliability are demanded (such as aerospace systems, atomic energy controls, sea floor repeaters, vehicle operating controls, medical devices for life support, etc.) are requested to consult with sales representatives before such use. The company will not be responsible for damages arising from such use without prior approval.

7.2 Precautions for Package Mounting

Package mounting may be either lead insertion type or surface mount type. In either case, for heat resistance during soldering, you should only mount under Cypress's recommended conditions. For detailed information about mount conditions, contact your sales representative.

• Lead Insertion Type

Mounting of lead insertion type packages onto printed circuit boards may be done by two methods: direct soldering on the board, or mounting by using a socket.

Direct mounting onto boards normally involves processes for inserting leads into through-holes on the board and using the flow soldering (wave soldering) method of applying liquid solder. In this case, the soldering process usually

causes leads to be subjected to thermal stress in excess of the absolute ratings for storage temperature. Mounting processes should conform to Cypress recommended mounting conditions.

If socket mounting is used, differences in surface treatment of the socket contacts and IC lead surfaces can lead to contact deterioration after long periods. For this reason it is recommended that the surface treatment of socket contacts and IC leads be verified before mounting.

- **Surface Mount Type**

Surface mount packaging has longer and thinner leads than lead-insertion packaging, and therefore leads are more easily deformed or bent. The use of packages with higher pin counts and narrower pin pitch results in increased susceptibility to open connections caused by deformed pins, or shorting due to solder bridges.

You must use appropriate mounting techniques. Cypress recommends the solder reflow method, and has established a ranking of mounting conditions for each product. Users are advised to mount packages in accordance with Cypress ranking of recommended conditions.

- **Lead-Free Packaging**

CAUTION: When ball grid array (BGA) packages with Sn-Ag-Cu balls are mounted using Sn-Pb eutectic soldering, junction strength may be reduced under some conditions of use.

- **Storage of Semiconductor Devices**

Because plastic chip packages are formed from plastic resins, exposure to natural environmental conditions will cause absorption of moisture. During mounting, the application of heat to a package that has absorbed moisture can cause surfaces to peel, reducing moisture resistance and causing packages to crack. To prevent, do the following:

- (1) Avoid exposure to rapid temperature changes, which cause moisture to condense inside the product. Store products in locations where temperature changes are slight.
- (2) Use dry boxes for product storage. Products should be stored below 70% relative humidity, and at temperatures between 5°C and 30°C.
When you open Dry Package that recommends humidity 40% to 70% relative humidity.
- (3) When necessary, Cypress packages semiconductor devices in highly moisture-resistant aluminum laminate bags, with a silica gel desiccant. Devices should be sealed in their aluminum laminate bags for storage.
- (4) Avoid storing packages where they are exposed to corrosive gases or high levels of dust.

- **Baking**

Packages that have absorbed moisture may be de-moisturized by baking (heat drying). Follow the Cypress recommended conditions for baking.

Condition: 125°C/24 h

- **Static Electricity**

Because semiconductor devices are particularly susceptible to damage by static electricity, you must take the following precautions:

- (1) Maintain relative humidity in the working environment between 40% and 70%.
Use of an apparatus for ion generation may be needed to remove electricity.
- (2) Electrically ground all conveyors, solder vessels, soldering irons and peripheral equipment.
- (3) Eliminate static body electricity by the use of rings or bracelets connected to ground through high resistance (on the level of 1 MΩ).
Wearing of conductive clothing and shoes, use of conductive floor mats and other measures to minimize shock loads is recommended.
- (4) Ground all fixtures and instruments, or protect with anti-static measures.
- (5) Avoid the use of styrofoam or other highly static-prone materials for storage of completed board assemblies.

7.3 Precautions for Use Environment

Reliability of semiconductor devices depends on ambient temperature and other conditions as described above.

For reliable performance, do the following:

(1) Humidity

Prolonged use in high humidity can lead to leakage in devices as well as printed circuit boards. If high humidity levels are anticipated, consider anti-humidity processing.

(2) Discharge of Static Electricity

When high-voltage charges exist close to semiconductor devices, discharges can cause abnormal operation. In such cases, use anti-static measures or processing to prevent discharges.

(3) Corrosive Gases, Dust, or Oil

Exposure to corrosive gases or contact with dust or oil may lead to chemical reactions that will adversely affect the device. If you use devices in such conditions, consider ways to prevent such exposure or to protect the devices.

(4) Radiation, Including Cosmic Radiation

Most devices are not designed for environments involving exposure to radiation or cosmic radiation. Users should provide shielding as appropriate.

(5) Smoke, Flame

CAUTION: Plastic molded devices are flammable, and therefore should not be used near combustible substances. If devices begin to smoke or burn, there is danger of the release of toxic gases.

Customers considering the use of Cypress products in other special environmental conditions should consult with sales representatives.

8. Notes On Device Handling

- Preventing latch-ups

When using the device, ensure that the voltage applied does not exceed the maximum voltage rating.

In a CMOS IC, if a voltage higher than V_{CC} or a voltage lower than V_{SS} is applied to an input/output pin that is neither a medium-withstand voltage pin nor a high-withstand voltage pin, or if a voltage out of the rating range of power supply voltage mentioned in “18.1 Absolute Maximum Ratings” of “Electrical Characteristics” is applied to the V_{CC} pin or the V_{SS} pin, a latch-up may occur.

When a latch-up occurs, power supply current increases significantly, which may cause a component to be thermally destroyed.

- Stabilizing supply voltage

Supply voltage must be stabilized.

A malfunction may occur when power supply voltage fluctuates rapidly even though the fluctuation is within the guaranteed operating range of the V_{CC} power supply voltage.

As a rule of voltage stabilization, suppress voltage fluctuation so that the fluctuation in V_{CC} ripple (p-p value) at the commercial frequency (50 Hz/60 Hz) does not exceed 10% of the standard V_{CC} value, and the transient fluctuation rate does not exceed 0.1 V/ms at a momentary fluctuation such as switching the power supply.

- Notes on using the external clock

When an external clock is used, oscillation stabilization wait time is required for power-on reset, wake-up from sub-clock mode or stop mode.

9. Pin Connection

- Treatment of unused pins**
 If an unused input pin is left unconnected, a component may be permanently damaged due to malfunctions or latch-ups. Always pull up or pull down an unused input pin through a resistor of at least 2 kΩ. Set an unused input/output pin to the output state and leave it unconnected, or set it to the input state and treat it the same as an unused input pin. If there is an unused output pin, leave it unconnected.
- Power supply pins**
 To reduce unnecessary electro-magnetic emission, prevent malfunctions of strobe signals due to an increase in the ground level, and conform to the total output current standard, always connect the V_{CC} pin and the V_{SS} pin to the power supply and ground outside the device. In addition, connect the current supply source to the V_{CC} pin and the V_{SS} pin with low impedance.
 It is also advisable to connect a ceramic capacitor of approximately 0.1 μF as a bypass capacitor between the V_{CC} pin and the V_{SS} pin at a location close to this device.
- DBG pin**
 Connect the DBG pin to an external pull-up resistor of 2 kΩ or above.
 After power-on, ensure that the DBG pin does not stay at “L” level until the reset output is released.
 The DBG pin becomes a communication pin in debug mode. Since the actual pull-up resistance depends on the tool used and the interconnection length, refer to the tool document when selecting a pull-up resistor.
- $\overline{\text{RST}}$ pin**
 Connect the $\overline{\text{RST}}$ pin to an external pull-up resistor of 2 kΩ or above.
 To prevent the device from unintentionally entering the reset mode due to noise, minimize the interconnection length between a pull-up resistor and the $\overline{\text{RST}}$ pin and that between a pull-up resistor and the V_{CC} pin when designing the layout of the printed circuit board.
 The PF2/ $\overline{\text{RST}}$ pin functions as the reset input/output pin after power-on. In addition, the reset output of the PF2/ $\overline{\text{RST}}$ pin can be enabled by the RSTOE bit in the SYSC register, and the reset input function and the general-purpose I/O function can be selected by the RSTEN bit in the SYSC register.
- C pin**
 Use a ceramic capacitor or a capacitor with equivalent frequency characteristics. The decoupling capacitor for the V_{CC} pin must have a capacitance equal to or larger than the capacitance of C_s. For the connection to a decoupling capacitor C_s, see the diagram below. To prevent the device from unintentionally entering a mode to which the device is not set to transit due to noise, minimize the distance between the C pin and C_s and the distance between C_s and the V_{SS} pin when designing the layout of a printed circuit board.

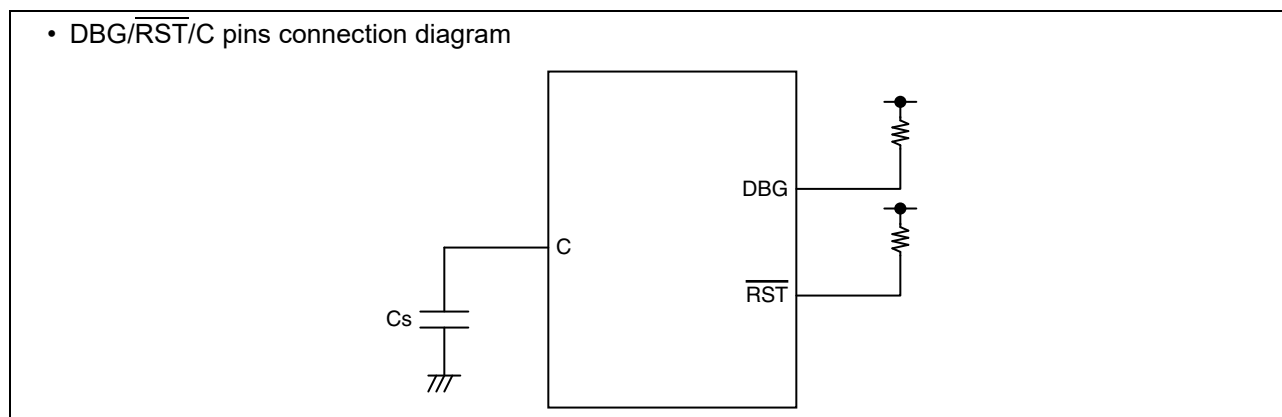

- Note on serial communication**
 In serial communication, reception of wrong data may occur due to noise or other causes. Therefore, design a printed

circuit board to prevent noise from occurring. Taking account of the reception of wrong data, take measures such as adding a checksum to the end of data in order to detect errors. If an error is detected, retransmit the data.

10. Block Diagram

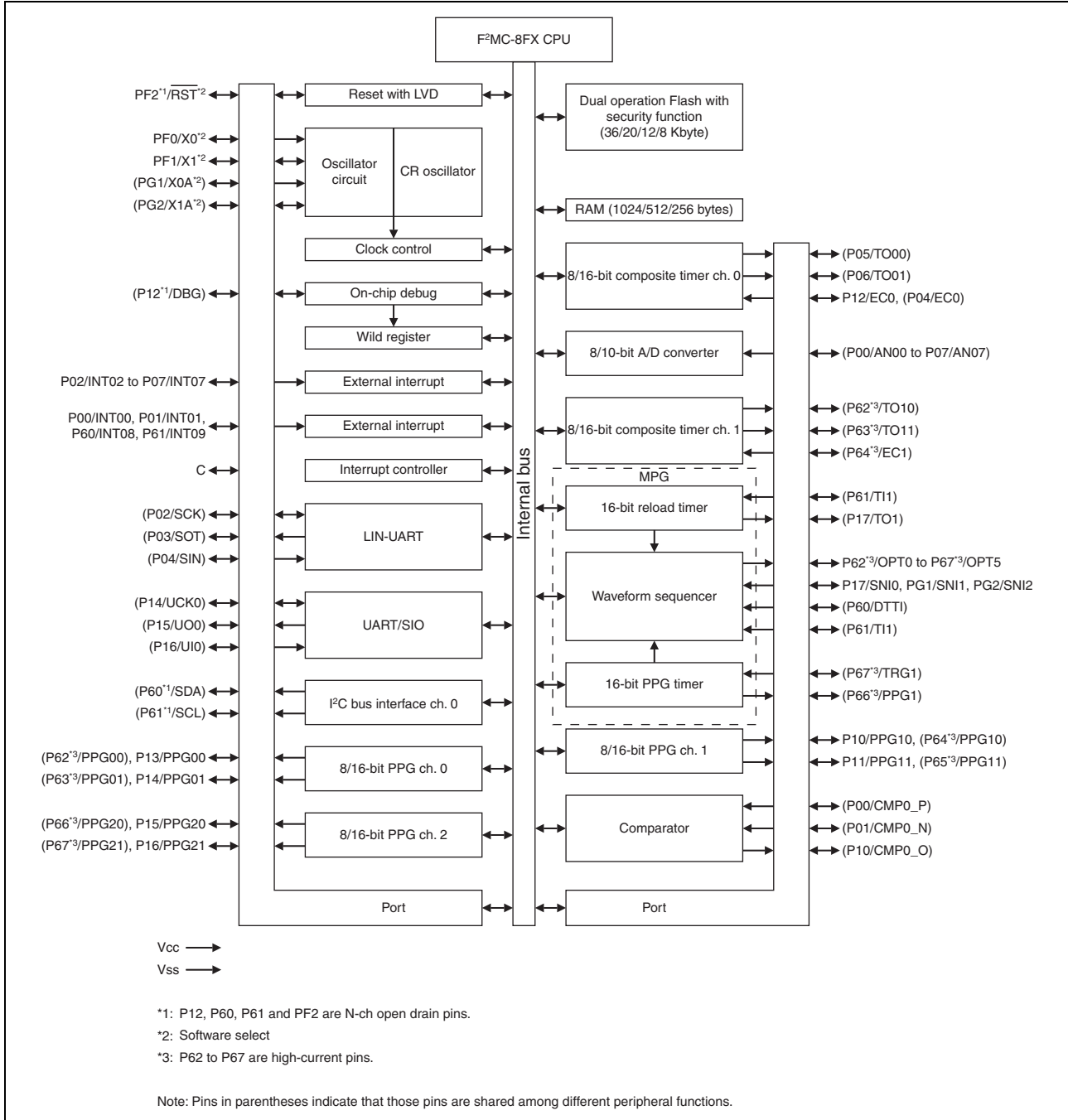

11. CPU Core

- Memory space

The memory space of the CY95630H Series is 64 Kbyte in size, and consists of an I/O area, an extended I/O area, a data area, and a program area. The memory space includes areas intended for specific purposes such as general-purpose registers and a vector table. The memory maps of the CY95630H Series are shown below.

- Memory maps

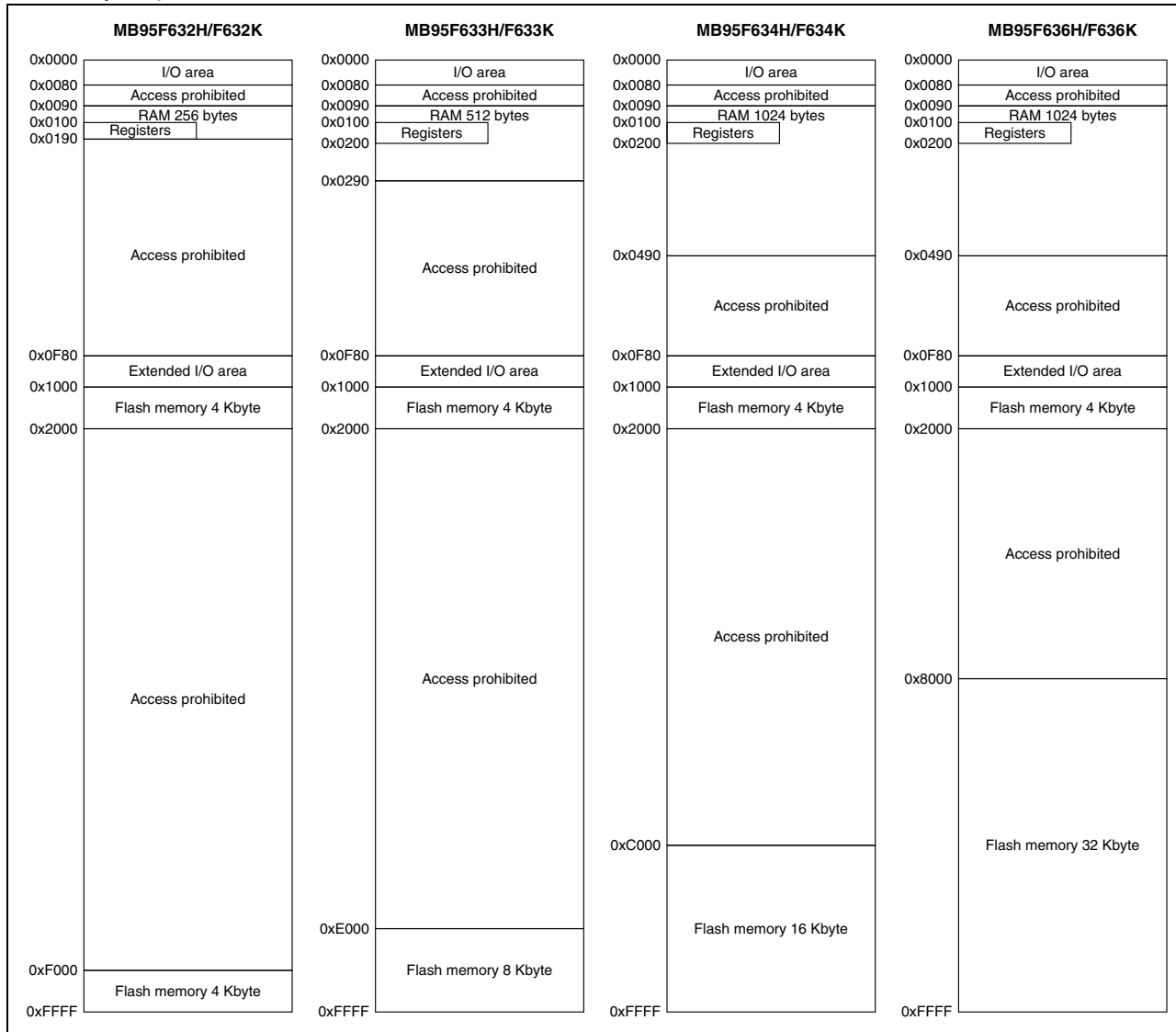

12. Memory Space

The memory space of the CY95630H Series is 64 Kbyte in size, and consists of an I/O area, an extended I/O area, a data area, and a program area. The memory space includes areas for specific applications such as general-purpose registers and a vector table.

- I/O area (addresses: 0x0000 to 0x007F)
 - This area contains the control registers and data registers for built-in peripheral functions.
 - As the I/O area forms part of the memory space, it can be accessed in the same way as the memory. It can also be accessed at high-speed by using direct addressing instructions.
- Extended I/O area (addresses: 0x0F80 to 0x0FFF)
 - This area contains the control registers and data registers for built-in peripheral functions.
 - As the extended I/O area forms part of the memory space, it can be accessed in the same way as the memory.
- Data area
 - Static RAM is incorporated in the data area as the internal data area.
 - The internal RAM size varies according to product.
 - The RAM area from 0x0090 to 0x00FF can be accessed at high-speed by using direct addressing instructions.
 - In CY95F636H/F636K, the area from 0x0090 to 0x047F is an extended direct addressing area. It can be accessed at high-speed by direct addressing instructions with a direct bank pointer set.
 - In CY95F634H/F634K, the area from 0x0090 to 0x047F is an extended direct addressing area. It can be accessed at high-speed by direct addressing instructions with a direct bank pointer set.
 - In CY95F633H/F633K, the area from 0x0090 to 0x028F is an extended direct addressing area. It can be accessed at high-speed by direct addressing instructions with a direct bank pointer set.
 - In CY95F632H/F632K, the area from 0x0090 to 0x018F is an extended direct addressing area. It can be accessed at high-speed by direct addressing instructions with a direct bank pointer set.
 - In CY95F633H/F633K/F634H/F634K/F636H/F636K, the area from 0x0100 to 0x01FF can be used as a general-purpose register area.
 - In CY95F632H/F632K, the area from 0x0100 to 0x018F can be used as a general-purpose register area.
- Program area
 - The Flash memory is incorporated in the program area as the internal program area.
 - The Flash memory size varies according to product.
 - The area from 0xFFC0 to 0xFFFF is used as the vector table.
 - The area from 0xFFBB to 0xFFBF is used to store data of the non-volatile register.

• Memory space map

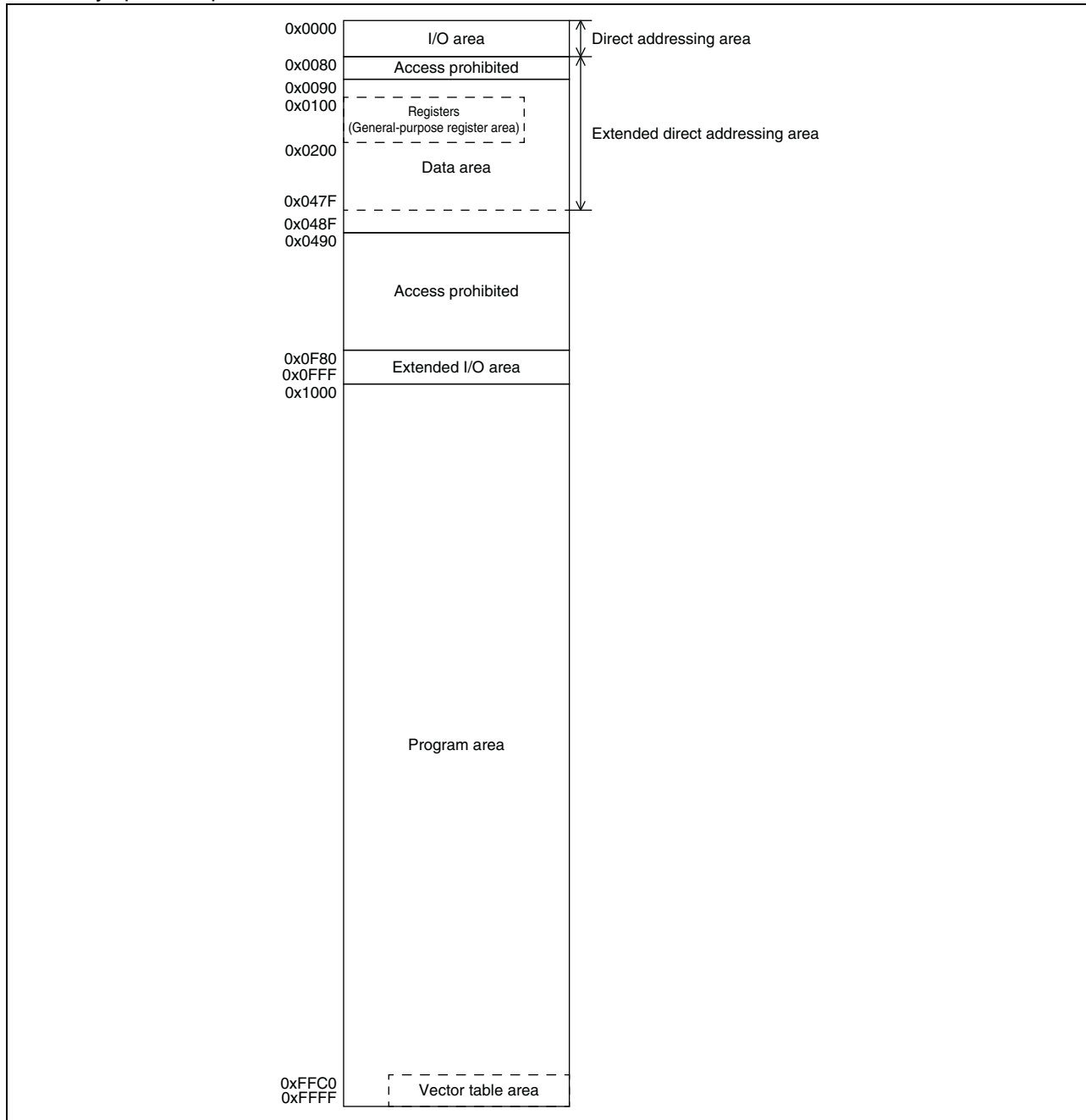

13. Areas For Specific Applications

The general-purpose register area and vector table area are used for the specific applications.

- General-purpose register area (Addresses: 0x0100 to 0x01FF*1)
 - This area contains the auxiliary registers used for 8-bit arithmetic operations, transfer, etc.
 - As this area forms part of the RAM area, it can also be used as conventional RAM.
 - When the area is used as general-purpose registers, general-purpose register addressing enables high-speed access with short instructions.
- Non-volatile register data area (Addresses: 0xFFBB to 0xFFBF)
 - The area from 0xFFBB to 0xFFBF is used to store data of the non-volatile register. For details, refer to “CHAPTER 26 NON-VOLATILE REGISTER (NVR) INTERFACE” in “New 8FX CY95630H Series Hardware Manual”.
- Vector table area (Addresses: 0xFFC0 to 0xFFFF)
 - This area is used as the vector table for vector call instructions (CALLV), interrupts, and resets.
 - The top of the Flash memory area is allocated to the vector table area. The start address of a service routine is set to an address in the vector table in the form of data.

“Interrupt Source Table” lists the vector table addresses corresponding to vector call instructions, interrupts, and resets.

For details, refer to “CHAPTER 4 RESET”, “CHAPTER 5 INTERRUPTS” and “A.2 Special Instruction ■ Special Instruction ● CALLV #vct” in “New 8FX CY95630H Series Hardware Manual”.

- Direct bank pointer and access area

Direct bank pointer (DP[2:0])	Operand-specified dir	Access area
0bXXX (It does not affect mapping.)	0x0000 to 0x007F	0x0000 to 0x007F
0b000 (Initial value)	0x0090 to 0x00FF	0x0090 to 0x00FF
0b001	0x0080 to 0x00FF	0x0100 to 0x017F
0b010		0x0180 to 0x01FF*1
0b011		0x0200 to 0x027F
0b100		0x0280 to 0x02FF*2
0b101		0x0300 to 0x037F
0b110		0x0380 to 0x03FF
0b111		0x0400 to 0x047F

*1: Due to the memory size limit, the available access area is up to “0x018F” in CY95F632H/F632K.

*2: Due to the memory size limit, the available access area is up to “0x028F” in CY95F633H/F633K.

14. I/O Map

Address	Register abbreviation	Register name	R/W	Initial value
0x0000	PDR0	Port 0 data register	R/W	0b00000000
0x0001	DDR0	Port 0 direction register	R/W	0b00000000
0x0002	PDR1	Port 1 data register	R/W	0b00000000
0x0003	DDR1	Port 1 direction register	R/W	0b00000000
0x0004	—	(Disabled)	—	—
0x0005	WATR	Oscillation stabilization wait time setting register	R/W	0b11111111
0x0006	PLLC	PLL control register	R/W	0b000X0000
0x0007	SYCC	System clock control register	R/W	0bXXX11011
0x0008	STBC	Standby control register	R/W	0b00000000
0x0009	RSRR	Reset source register	R/W	0b000XXXXX
0x000A	TBTC	Time-base timer control register	R/W	0b00000000
0x000B	WPCR	Watch prescaler control register	R/W	0b00000000
0x000C	WDTC	Watchdog timer control register	R/W	0b00XX0000
0x000D	SYCC2	System clock control register 2	R/W	0bXXXX0011
0x000E	STBC2	Standby control register 2	R/W	0b00000000
0x000F to 0x0015	—	(Disabled)	—	—
0x0016	PDR6	Port 6 data register	R/W	0b00000000
0x0017	DDR6	Port 6 direction register	R/W	0b00000000
0x0018 to 0x0027	—	(Disabled)	—	—
0x0028	PDRF	Port F data register	R/W	0b00000000
0x0029	DDRF	Port F direction register	R/W	0b00000000
0x002A	PDRG	Port G data register	R/W	0b00000000
0x002B	DDRG	Port G direction register	R/W	0b00000000
0x002C	PUL0	Port 0 pull-up register	R/W	0b00000000
0x002D	PUL1	Port 1 pull-up register	R/W	0b00000000
0x002E to 0x0032	—	(Disabled)	—	—
0x0033	PUL6	Port 6 pull-up register	R/W	0b00000000
0x0034	—	(Disabled)	—	—
0x0035	PULG	Port G pull-up register	R/W	0b00000000
0x0036	T01CR1	8/16-bit composite timer 01 status control register 1	R/W	0b00000000

Address	Register abbreviation	Register name	R/W	Initial value
0x0037	T00CR1	8/16-bit composite timer 00 status control register 1	R/W	0b00000000
0x0038	T11CR1	8/16-bit composite timer 11 status control register 1	R/W	0b00000000
0x0039	T10CR1	8/16-bit composite timer 10 status control register 1	R/W	0b00000000
0x003A	PC01	8/16-bit PPG timer 01 control register	R/W	0b00000000
0x003B	PC00	8/16-bit PPG timer 00 control register	R/W	0b00000000
0x003C	PC11	8/16-bit PPG timer 11 control register	R/W	0b00000000
0x003D	PC10	8/16-bit PPG timer 10 control register	R/W	0b00000000
0x003E	PC21	8/16-bit PPG timer 21 control register	R/W	0b00000000
0x003F	PC20	8/16-bit PPG timer 20 control register	R/W	0b00000000
0x0040	TMCSRH1	16-bit reload timer control status register (upper)	R/W	0b00000000
0x0041	TMCSRL1	16-bit reload timer control status register (lower)	R/W	0b00000000
0x0042	CMR0C	Comparator control register	R/W	0b00000101
0x0043	—	(Disabled)	—	—
0x0044	PCNTH1	16-bit PPG status control register (upper)	R/W	0b00000000
0x0045	PCNTL1	16-bit PPG status control register (lower)	R/W	0b00000000
0x0046, 0x0047	—	(Disabled)	—	—
0x0048	EIC00	External interrupt circuit control register ch. 0/ch. 1	R/W	0b00000000
0x0049	EIC10	External interrupt circuit control register ch. 2/ch. 3	R/W	0b00000000
0x004A	EIC20	External interrupt circuit control register ch. 4/ch. 5	R/W	0b00000000
0x004B	EIC30	External interrupt circuit control register ch. 6/ch. 7	R/W	0b00000000
0x004C	EIC01	External interrupt circuit control register ch. 8/ch. 9	R/W	0b00000000
0x004D	—	(Disabled)	—	—
0x004E	LVDR	LVD reset voltage selection ID register	R/W	0b00000000
0x004F	—	(Disabled)	—	—
0x0050	SCR	LIN-UART serial control register	R/W	0b00000000
0x0051	SMR	LIN-UART serial mode register	R/W	0b00000000
0x0052	SSR	LIN-UART serial status register	R/W	0b00001000
0x0053	RDR	LIN-UART receive data register	R/W	0b00000000
	TDR	LIN-UART transmit data register		
0x0054	ESCR	LIN-UART extended status control register	R/W	0b00000100
0x0055	ECCR	LIN-UART extended communication control register	R/W	0b000000XX
0x0056	SMC10	UART/SIO serial mode control register 1	R/W	0b00000000
0x0057	SMC20	UART/SIO serial mode control register 2	R/W	0b00100000
0x0058	SSR0	UART/SIO serial status and data register	R/W	0b00000001
0x0059	TDR0	UART/SIO serial output data register	R/W	0b00000000

Address	Register abbreviation	Register name	R/W	Initial value
0x005A	RDR0	UART/SIO serial input data register	R	0b00000000
0x005B to 0x005F	—	(Disabled)	—	—
0x0060	IBCR00	I ² C bus control register 0 ch. 0	R/W	0b00000000
0x0061	IBCR10	I ² C bus control register 1 ch. 0	R/W	0b00000000
0x0062	IBSR0	I ² C bus status register ch. 0	R/W	0b00000000
0x0063	IDDR0	I ² C data register ch. 0	R/W	0b00000000
0x0064	IAAR0	I ² C address register ch. 0	R/W	0b00000000
0x0065	ICCR0	I ² C clock control register ch. 0	R/W	0b00000000
0x0066	OPCUR	16-bit MPG output control register (upper)	R/W	0b00000000
0x0067	OPCLR	16-bit MPG output control register (lower)	R/W	0b00000000
0x0068	IPCUR	16-bit MPG input control register (upper)	R/W	0b00000000
0x0069	IPCLR	16-bit MPG input control register (lower)	R/W	0b00000000
0x006A	NCCR	16-bit MPG noise cancellation control register	R/W	0b00000000
0x006B	TCSR	16-bit MPG timer control status register	R/W	0b00000000
0x006C	ADC1	8/10-bit A/D converter control register 1	R/W	0b00000000
0x006D	ADC2	8/10-bit A/D converter control register 2	R/W	0b00000000
0x006E	ADDH	8/10-bit A/D converter data register (upper)	R/W	0b00000000
0x006F	ADDL	8/10-bit A/D converter data register (lower)	R/W	0b00000000
0x0070	—	(Disabled)	—	—
0x0071	FSR2	Flash memory status register 2	R/W	0b00000000
0x0072	FSR	Flash memory status register	R/W	0b000X0000
0x0073	SWRE0	Flash memory sector write control register 0	R/W	0b00000000
0x0074	FSR3	Flash memory status register 3	R	0b000XXXXX
0x0075	FSR4	Flash memory status register 4	R/W	0b00000000
0x0076	WREN	Wild register address compare enable register	R/W	0b00000000
0x0077	WROR	Wild register data test setting register	R/W	0b00000000
0x0078	—	Mirror of register bank pointer (RP) and direct bank pointer (DP)	—	—
0x0079	ILR0	Interrupt level setting register 0	R/W	0b11111111
0x007A	ILR1	Interrupt level setting register 1	R/W	0b11111111
0x007B	ILR2	Interrupt level setting register 2	R/W	0b11111111
0x007C	ILR3	Interrupt level setting register 3	R/W	0b11111111
0x007D	ILR4	Interrupt level setting register 4	R/W	0b11111111
0x007E	ILR5	Interrupt level setting register 5	R/W	0b11111111
0x007F	—	(Disabled)	—	—

Address	Register abbreviation	Register name	R/W	Initial value
0x0F80	WRARH0	Wild register address setting register (upper) ch. 0	R/W	0b00000000
0x0F81	WRARL0	Wild register address setting register (lower) ch. 0	R/W	0b00000000
0x0F82	WRDR0	Wild register data setting register ch. 0	R/W	0b00000000
0x0F83	WRARH1	Wild register address setting register (upper) ch. 1	R/W	0b00000000
0x0F84	WRARL1	Wild register address setting register (lower) ch. 1	R/W	0b00000000
0x0F85	WRDR1	Wild register data setting register ch. 1	R/W	0b00000000
0x0F86	WRARH2	Wild register address setting register (upper) ch. 2	R/W	0b00000000
0x0F87	WRARL2	Wild register address setting register (lower) ch. 2	R/W	0b00000000
0x0F88	WRDR2	Wild register data setting register ch. 2	R/W	0b00000000
0x0F89 to 0x0F91	—	(Disabled)	—	—
0x0F92	T01CR0	8/16-bit composite timer 01 status control register 0	R/W	0b00000000
0x0F93	T00CR0	8/16-bit composite timer 00 status control register 0	R/W	0b00000000
0x0F94	T01DR	8/16-bit composite timer 01 data register	R/W	0b00000000
0x0F95	T00DR	8/16-bit composite timer 00 data register	R/W	0b00000000
0x0F96	TMCR0	8/16-bit composite timer 00/01 timer mode control register	R/W	0b00000000
0x0F97	T11CR0	8/16-bit composite timer 11 status control register 0	R/W	0b00000000
0x0F98	T10CR0	8/16-bit composite timer 10 status control register 0	R/W	0b00000000
0x0F99	T11DR	8/16-bit composite timer 11 data register	R/W	0b00000000
0x0F9A	T10DR	8/16-bit composite timer 10 data register	R/W	0b00000000
0x0F9B	TMCR1	8/16-bit composite timer 10/11 timer mode control register	R/W	0b00000000
0x0F9C	PPS01	8/16-bit PPG01 cycle setting buffer register	R/W	0b11111111
0x0F9D	PPS00	8/16-bit PPG00 cycle setting buffer register	R/W	0b11111111
0x0F9E	PDS01	8/16-bit PPG01 duty setting buffer register	R/W	0b11111111
0x0F9F	PDS00	8/16-bit PPG00 duty setting buffer register	R/W	0b11111111
0x0FA0	PPS11	8/16-bit PPG11 cycle setting buffer register	R/W	0b11111111
0x0FA1	PPS10	8/16-bit PPG10 cycle setting buffer register	R/W	0b11111111
0x0FA2	PDS11	8/16-bit PPG11 duty setting buffer register	R/W	0b11111111
0x0FA3	PDS10	8/16-bit PPG10 duty setting buffer register	R/W	0b11111111
0x0FA4	PPGS	8/16-bit PPG start register	R/W	0b00000000
0x0FA5	REVC	8/16-bit PPG output inversion register	R/W	0b00000000
0x0FA6	PPS21	8/16-bit PPG21 cycle setting buffer register	R/W	0b11111111
0x0FA7	PPS20	8/16-bit PPG20 cycle setting buffer register	R/W	0b11111111

Address	Register abbreviation	Register name	R/W	Initial value
0x0FA8	TMRH1	16-bit reload timer timer register (upper)	R/W	0b00000000
	TMRLRH1	16-bit reload timer reload register (upper)		
0x0FA9	TMRL1	16-bit reload timer timer register (lower)	R/W	0b00000000
	TMRLRL1	16-bit reload timer reload register (lower)		
0x0FAA	PDS21	8/16-bit PPG21 duty setting buffer register	R/W	0b11111111
0x0FAB	PDS20	8/16-bit PPG20 duty setting buffer register	R/W	0b11111111
0x0FAC to 0x0FAF	—	(Disabled)	—	—
0x0FB0	PDCRH1	16-bit PPG downcounter register (upper)	R	0b00000000
0x0FB1	PDCRL1	16-bit PPG downcounter register (lower)	R	0b00000000
0x0FB2	PCSRH1	16-bit PPG cycle setting buffer register (upper)	R/W	0b11111111
0x0FB3	PCSRL1	16-bit PPG cycle setting buffer register (lower)	R/W	0b11111111
0x0FB4	PDUTH1	16-bit PPG duty setting buffer register (upper)	R/W	0b11111111
0x0FB5	PDUTL1	16-bit PPG duty setting buffer register (lower)	R/W	0b11111111
0x0FB6 to 0x0FBB	—	(Disabled)	—	—
0x0FBC	BGR1	LIN-UART baud rate generator register 1	R/W	0b00000000
0x0FBD	BGR0	LIN-UART baud rate generator register 0	R/W	0b00000000
0x0FBE	PSSR0	UART/SIO dedicated baud rate generator prescaler select register	R/W	0b00000000
0x0FBF	BRSR0	UART/SIO dedicated baud rate generator baud rate setting register	R/W	0b00000000
0x0FC0 to 0x0FC2	—	(Disabled)	—	—
0x0FC3	AIDRL	A/D input disable register (lower)	R/W	0b00000000
0x0FC4	OPDBRH0	16-bit MPG output data buffer register (upper) ch. 0	R/W	0b00000000
0x0FC5	OPDBRL0	16-bit MPG output data buffer register (lower) ch. 0	R/W	0b00000000
0x0FC6	OPDBRH1	16-bit MPG output data buffer register (upper) ch. 1	R/W	0b00000000
0x0FC7	OPDBRL1	16-bit MPG output data buffer register (lower) ch. 1	R/W	0b00000000
0x0FC8	OPDBRH2	16-bit MPG output data buffer register (upper) ch. 2	R/W	0b00000000
0x0FC9	OPDBRL2	16-bit MPG output data buffer register (lower) ch. 2	R/W	0b00000000
0x0FCA	OPDBRH3	16-bit MPG output data buffer register (upper) ch. 3	R/W	0b00000000
0x0FCB	OPDBRL3	16-bit MPG output data buffer register (lower) ch. 3	R/W	0b00000000
0x0FCC	OPDBRH4	16-bit MPG output data buffer register (upper) ch. 4	R/W	0b00000000
0x0FCD	OPDBRL4	16-bit MPG output data buffer register (lower) ch. 4	R/W	0b00000000

Address	Register abbreviation	Register name	R/W	Initial value
0x0FCE	OPDBRH5	16-bit MPG output data buffer register (upper) ch. 5	R/W	0b00000000
0x0FCF	OPDBRL5	16-bit MPG output data buffer register (lower) ch. 5	R/W	0b00000000
0x0FD0	OPDBRH6	16-bit MPG output data buffer register (upper) ch. 6	R/W	0b00000000
0x0FD1	OPDBRL6	16-bit MPG output data buffer register (lower) ch. 6	R/W	0b00000000
0x0FD2	OPDBRH7	16-bit MPG output data buffer register (upper) ch. 7	R/W	0b00000000
0x0FD3	OPDBRL7	16-bit MPG output data buffer register (lower) ch. 7	R/W	0b00000000
0x0FD4	OPDBRH8	16-bit MPG output data buffer register (upper) ch. 8	R/W	0b00000000
0x0FD5	OPDBRL8	16-bit MPG output data buffer register (lower) ch. 8	R/W	0b00000000
0x0FD6	OPDBRH9	16-bit MPG output data buffer register (upper) ch. 9	R/W	0b00000000
0x0FD7	OPDBRL9	16-bit MPG output data buffer register (lower) ch. 9	R/W	0b00000000
0x0FD8	OPDBRHA	16-bit MPG output data buffer register (upper) ch. A	R/W	0b00000000
0x0FD9	OPDBRLA	16-bit MPG output data buffer register (lower) ch. A	R/W	0b00000000
0x0FDA	OPDBRHB	16-bit MPG output data buffer register (upper) ch. B	R/W	0b00000000
0x0FDB	OPDBRLB	16-bit MPG output data buffer register (lower) ch. B	R/W	0b00000000
0x0FDC	OPDUR	16-bit MPG output data register (upper)	R	0b0000XXXX
0x0FDD	OPDLR	16-bit MPG output data register (lower)	R	0bXXXXXXXXXX
0x0FDE	CPCUR	16-bit MPG compare clear register (upper)	R/W	0bXXXXXXXXXX
0x0FDF	CPCLR	16-bit MPG compare clear register (lower)	R/W	0bXXXXXXXXXX
0x0FE0, 0x0FE1	—	(Disabled)	—	—
0x0FE2	TMBUR	16-bit MPG timer buffer register (upper)	R	0bXXXXXXXXXX
0x0FE3	TMBLR	16-bit MPG timer buffer register (lower)	R	0bXXXXXXXXXX
0x0FE4	CRTH	Main CR clock trimming register (upper)	R/W	0b000XXXXX
0x0FE5	CRTL	Main CR clock trimming register (lower)	R/W	0b000XXXXX
0x0FE6	—	(Disabled)	—	—
0x0FE7	CRTDA	Main CR clock temperature dependent adjustment register	R/W	0b000XXXXX
0x0FE8	SYSC	System configuration register	R/W	0b11000011
0x0FE9	CMCR	Clock monitoring control register	R/W	0b00000000
0x0FEA	CMDR	Clock monitoring data register	R	0b00000000
0x0FEB	WDTH	Watchdog timer selection ID register (upper)	R	0bXXXXXXXXXX
0x0FEC	WDTL	Watchdog timer selection ID register (lower)	R	0bXXXXXXXXXX
0x0FED, 0x0FEE	—	(Disabled)	—	—
0x0FEF	WICR	Interrupt pin selection circuit control register	R/W	0b01000000
0x0FF0 to 0x0FFF	—	(Disabled)	—	—

- R/W access symbols
R/W : Readable/Writable
R : Read only
- Initial value symbols
0 : The initial value of this bit is “0”.
1 : The initial value of this bit is “1”.
X : The initial value of this bit is undefined.

Note: Do not write to an address that is “(Disabled)”. If a “(Disabled)” address is read, an indeterminate value is returned.

15. I/O Ports

- List of port registers

Register name		Read/Write	Initial value
Port 0 data register	PDR0	R, RM/W	0b00000000
Port 0 direction register	DDR0	R/W	0b00000000
Port 1 data register	PDR1	R, RM/W	0b00000000
Port 1 direction register	DDR1	R/W	0b00000000
Port 6 data register	PDR6	R, RM/W	0b00000000
Port 6 direction register	DDR6	R/W	0b00000000
Port F data register	PDRF	R, RM/W	0b00000000
Port F direction register	DDRF	R/W	0b00000000
Port G data register	PDRG	R, RM/W	0b00000000
Port G direction register	DDRG	R/W	0b00000000
Port 0 pull-up register	PUL0	R/W	0b00000000
Port 1 pull-up register	PUL1	R/W	0b00000000
Port 6 pull-up register	PUL6	R/W	0b00000000
Port G pull-up register	PULG	R/W	0b00000000
A/D input disable register (lower)	AIDRL	R/W	0b00000000

R/W : Readable/writable (The read value is the same as the write value.)

R, RM/W : Readable/writable (The read value is different from the write value. The write value is read by the read-modify-write (RMW) type of instruction.)

15.1 Port 0

Port 0 is a general-purpose I/O port. This section focuses on its functions as a general-purpose I/O port. For details of peripheral functions, refer to their respective chapters in “New 8FX CY95630H Series Hardware Manual”.

15.1.1 Port 0 configuration

Port 0 is made up of the following elements.

- General-purpose I/O pins/peripheral function I/O pins
- Port 0 data register (PDR0)
- Port 0 direction register (DDR0)
- Port 0 pull-up register (PUL0)
- A/D input disable register (lower) (AIDRL)

15.1.2 Block diagrams of port 0

• P00/INT00/AN00/CMP0_P pin

This pin has the following peripheral functions:

- External interrupt circuit input pin (INT00)
- 8/10-bit A/D converter analog input pin (AN00)
- Comparator non-inverting analog input (positive input) pin (CMP0_P)

• P01/INT01/AN01/CMP0_N pin

This pin has the following peripheral functions:

- External interrupt circuit input pin (INT01)
- 8/10-bit A/D converter analog input pin (AN01)
- Comparator inverting analog input (negative input) pin (CMP0_N)

- Block diagram of P00/INT00/AN00/CMP0_P and P01/INT01/AN01/CMP0_N

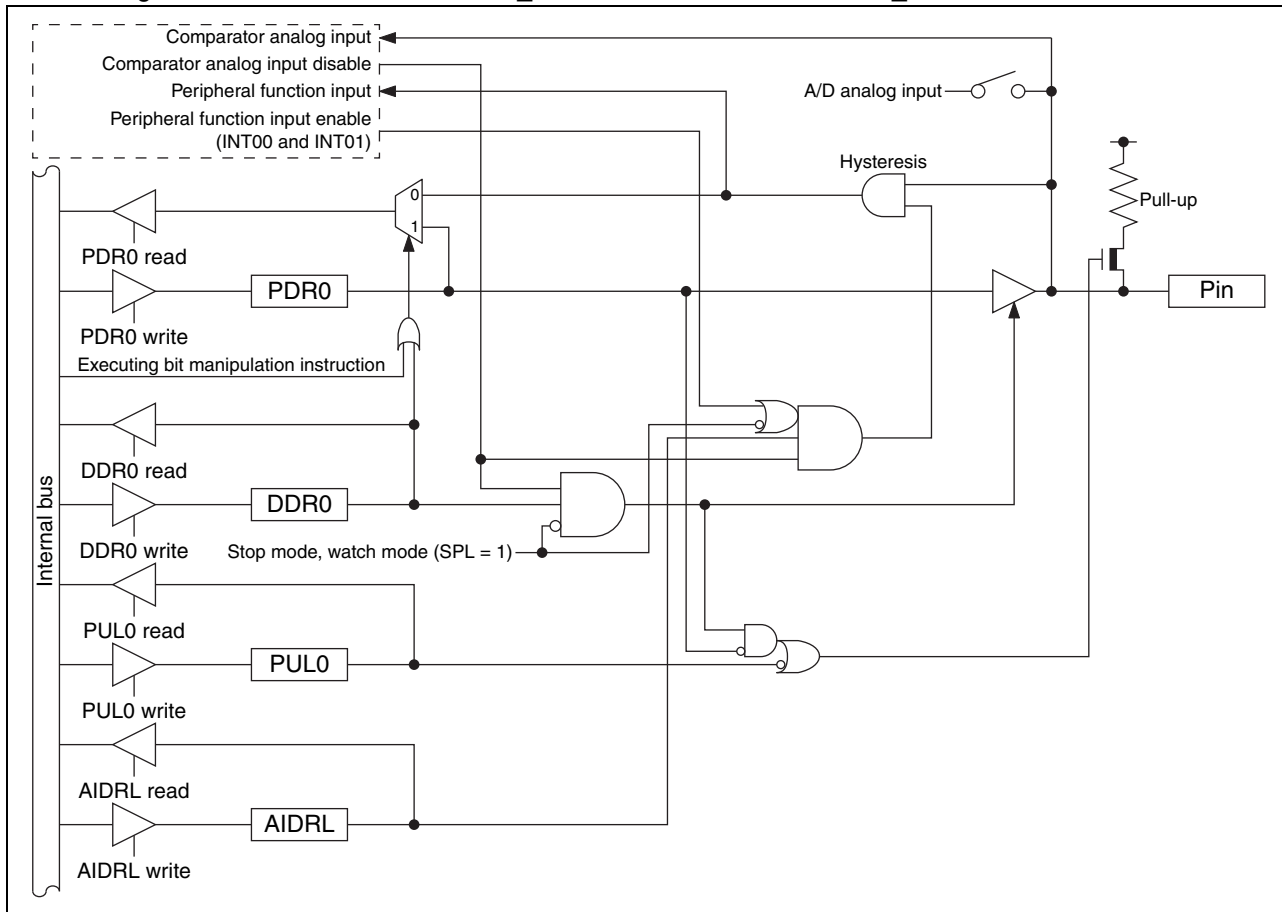

- P02/INT02/AN02/SCK pin
This pin has the following peripheral functions:
 - External interrupt circuit input pin (INT02)
 - 8/10-bit A/D converter analog input pin (AN02)
 - LIN-UART clock I/O pin (SCK)

- P03/INT03/AN03/SOT pin
This pin has the following peripheral functions:
 - External interrupt circuit input pin (INT03)
 - 8/10-bit A/D converter analog input pin (AN03)
 - LIN-UART data output pin (SOT)

- P05/INT05/AN05/TO00 pin
This pin has the following peripheral functions:
 - External interrupt circuit input pin (INT05)
 - 8/10-bit A/D converter analog input pin (AN05)
 - 8/16-bit composite timer ch. 0 output pin (TO00)

- P06/INT06/AN06/TO01 pin
This pin has the following peripheral functions:
 - External interrupt circuit input pin (INT06)
 - 8/10-bit A/D converter analog input pin (AN06)
 - 8/16-bit composite timer ch. 0 output pin (TO01)

- Block diagram of P02/INT02/AN02/SCK, P03/INT03/AN03/SOT, P05/INT05/AN05/TO00 and P06/INT06/AN06/TO01

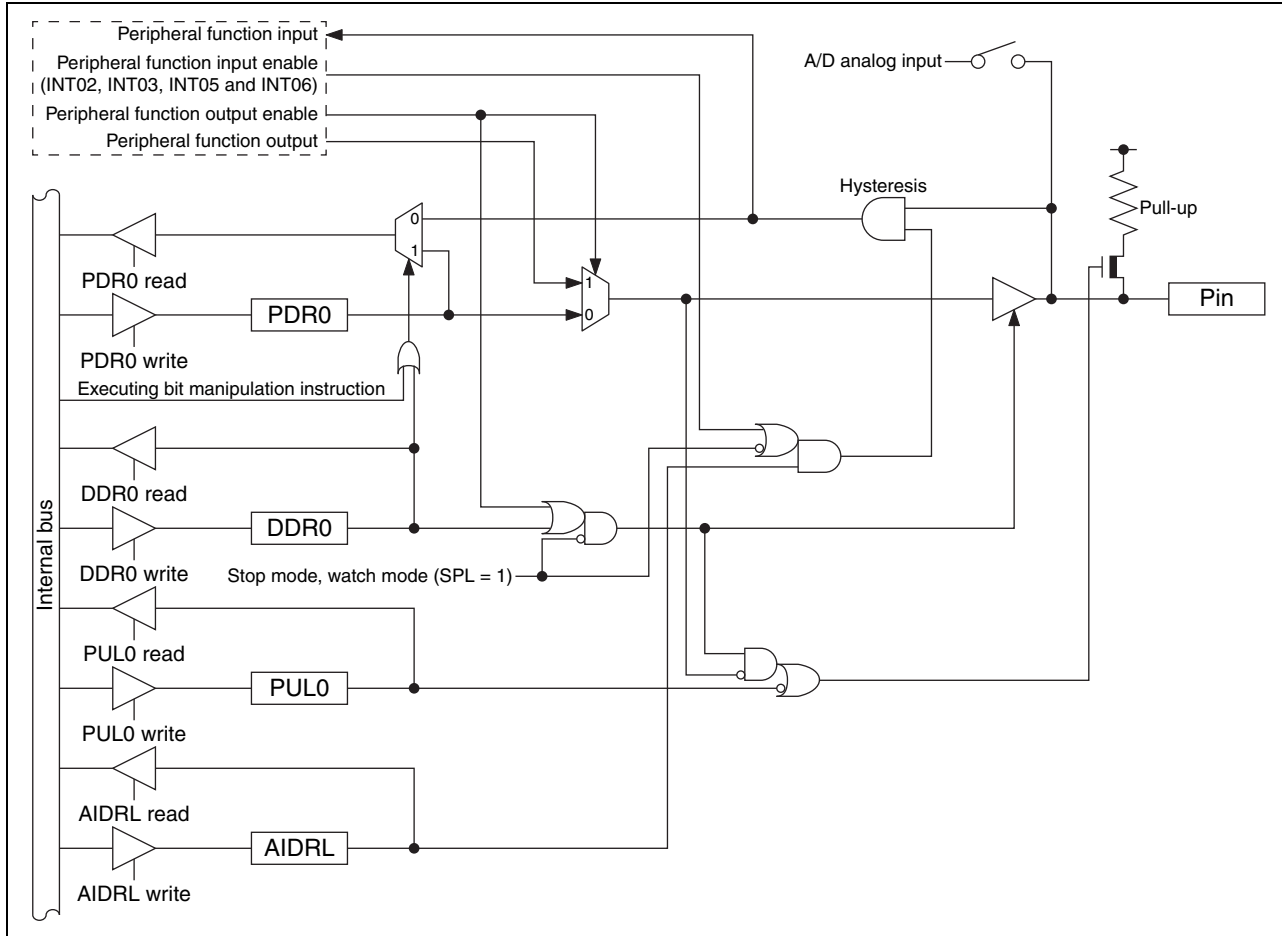

- P04/INT04/AN04/SIN/EC0 pin
 - This pin has the following peripheral functions:
 - External interrupt circuit input pin (INT04)
 - 8/10-bit A/D converter analog input pin (AN04)
 - LIN-UART data input pin (SIN)
 - 8/16-bit composite timer ch. 0 clock input pin (EC0)

• Block diagram of P04/INT04/AN04/SIN/EC0

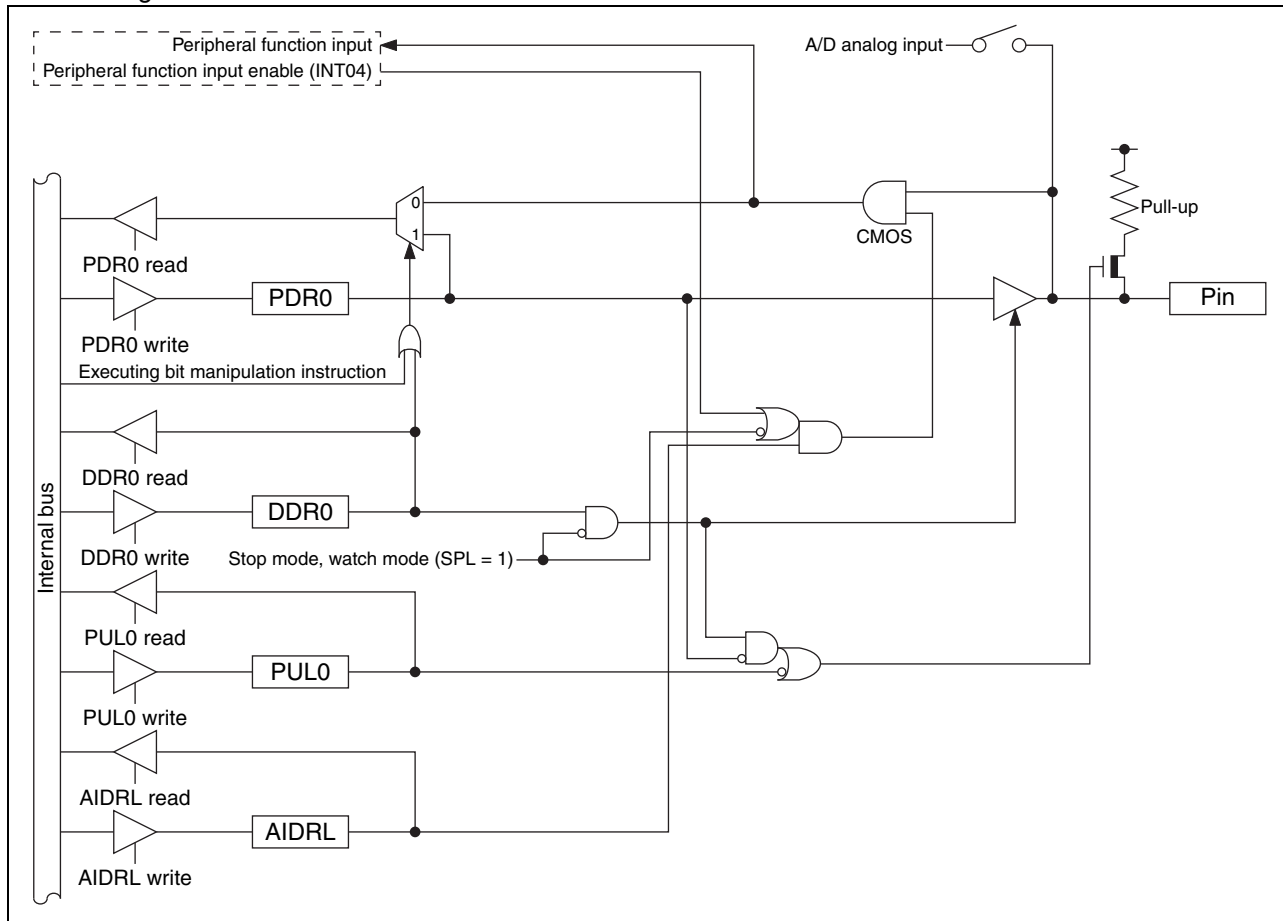

- P07/INT07/AN07 pin
 - This pin has the following peripheral functions:
 - External interrupt circuit input pin (INT07)
 - 8/10-bit A/D converter analog input pin (AN07)

• Block diagram of P07/INT07/AN07

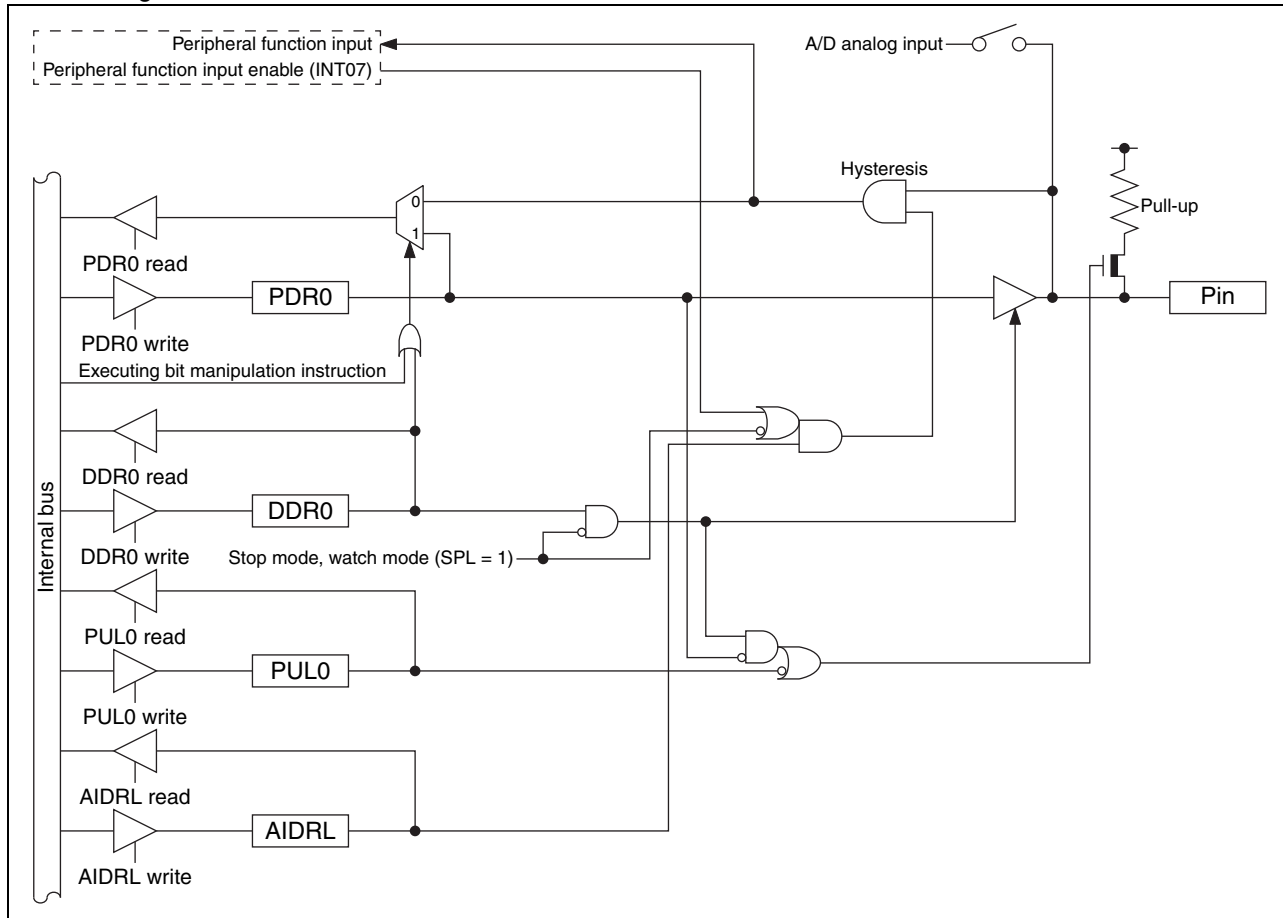

15.1.3 Port 0 registers

- Port 0 register functions

Register abbreviation	Data	Read	Read by read-modify-write (RMW) instruction	Write
PDR0	0	Pin state is “L” level.	PDR0 value is “0”.	As output port, outputs “L” level.
	1	Pin state is “H” level.	PDR0 value is “1”.	As output port, outputs “H” level.
DDR0	0	Port input enabled		
	1	Port output enabled		
PUL0	0	Pull-up disabled		
	1	Pull-up enabled		
AIDRL	0	Analog input enabled		
	1	Port input enabled		

- Correspondence between registers and pins for port 0

	Correspondence between related register bits and pins							
Pin name	P07	P06	P05	P04	P03	P02	P01	P00
PDR0	bit7	bit6	bit5	bit4	bit3	bit2	bit1	bit0
DDR0								
PUL0								
AIDRL								

15.1.4 Port 0 operations

- Operation as an output port
 - A pin becomes an output port if the bit in the DDR0 register corresponding to that pin is set to “1”.
 - For a pin shared with other peripheral functions, disable the output of such peripheral functions.
 - When a pin is used as an output port, it outputs the value of the PDR0 register to external pins.
 - If data is written to the PDR0 register, the value is stored in the output latch and is output to the pin set as an output port as it is.
 - Reading the PDR0 register returns the PDR0 register value.
- Operation as an input port
 - A pin becomes an input port if the bit in the DDR0 register corresponding to that pin is set to “0”.
 - For a pin shared with other peripheral functions, disable the output of such peripheral functions.
 - When using a pin shared with the analog input function as an input port, set the corresponding bit in the A/D input disable register (lower) (AIDRL) to “1”.
 - If data is written to the PDR0 register, the value is stored in the output latch but is not output to the pin set as an input port.
 - Reading the PDR0 register returns the pin value. However, if the read-modify-write (RMW) type of instruction is used to read the PDR0 register, the PDR0 register value is returned.
- Operation as a peripheral function output pin
 - A pin becomes a peripheral function output pin if the peripheral output function is enabled by setting the output enable bit of a peripheral function corresponding to that pin.
 - The pin value can be read from the PDR0 register even if the peripheral function output is enabled. Therefore, the output value of a peripheral function can be read by the read operation on the PDR0 register. However, if the read-modify-write (RMW) type of instruction is used to read the PDR0 register, the PDR0 register value is returned.

- Operation as a peripheral function input pin
 - To set a pin as an input port, set the bit in the DDR0 register corresponding to the input pin of a peripheral function to “0”.
 - When using a pin shared with the analog input function as another peripheral function input pin, configure it as an input port by setting the bit in the AIDRL register corresponding to that pin to “1”.
 - Reading the PDR0 register returns the pin value, regardless of whether the peripheral function uses that pin as its input pin. However, if the read-modify-write (RMW) type of instruction is used to read the PDR0 register, the PDR0 register value is returned.
- Operation at reset

If the CPU is reset, all bits in the DDR0 register are initialized to “0” and port input is enabled. As for a pin shared with analog input, its port input is disabled because the AIDRL register is initialized to “0”.
- Operation in stop mode and watch mode
 - If the pin state setting bit in the standby control register (STBC:SPL) is set to “1” and the device transits to stop mode or watch mode, the pin is compulsorily made to enter the high impedance state regardless of the DDR0 register value. The input of that pin is locked to “L” level and blocked in order to prevent leaks due to input open. However, if the interrupt input is enabled for the external interrupt (INT00 to INT07), the input is enabled and not blocked.
 - If the pin state setting bit is “0”, the state of the port I/O or that of the peripheral function I/O remains unchanged and the output level is maintained.
- Operation as an analog input pin
 - Set the bit in the DDR0 register bit corresponding to the analog input pin to “0” and the bit corresponding to that pin in the AIDRL register to “0”.
 - For a pin shared with other peripheral functions, disable the output of such peripheral functions. In addition, set the corresponding bit in the PUL0 register to “0”.
- Operation as an external interrupt input pin
 - Set the bit in the DDR0 register corresponding to the external interrupt input pin to “0”.
 - For a pin shared with other peripheral functions, disable the output of such peripheral functions.
 - The pin value is always input to the external interrupt circuit. When using a pin for a function other than the interrupt, disable the external interrupt function corresponding to that pin.
- Operation of the pull-up register

Setting the bit in the PUL0 register to “1” makes the pull-up resistor be internally connected to the pin. When the pin output is “L” level, the pull-up resistor is disconnected regardless of the value of the PUL0 register.
- Operation as a comparator input pin (only for P00 and P01)
 - Set the bit in the AIDRL register corresponding to the comparator input pin to “0”.
 - Regardless of the value of the PDR0 register and that of the DDR0 register, if the comparator analog input enable bit in the comparator control register (CMR0C:VCID) is set to “0”, the comparator input function is enabled.
 - To disable the comparator input function, set the VCID bit to “1”.
 - For details of the comparator, refer to “CHAPTER 27 COMPARATOR” in “New 8FX CY95630H Series Hardware Manual”.

15.2 Port 1

Port 1 is a general-purpose I/O port. This section focuses on its functions as a general-purpose I/O port. For details of peripheral functions, refer to their respective chapters in “New 8FX CY95630H Series Hardware Manual”.

15.2.1 Port 1 configuration

Port 1 is made up of the following elements.

- General-purpose I/O pins/peripheral function I/O pins
- Port 1 data register (PDR1)
- Port 1 direction register (DDR1)
- Port 1 pull-up register (PUL1)

15.2.2 Block diagrams of port 1

- P10/PPG10/CMP0_O pin
This pin has the following peripheral functions:
 - 8/16-bit PPG ch. 1 output pin (PPG10)
 - Comparator digital output pin (CMP0_O)
- P11/PPG11 pin
This pin has the following peripheral function:
 - 8/16-bit PPG ch. 1 output pin (PPG11)
- P13/PPG00 pin
This pin has the following peripheral function:
 - 8/16-bit PPG ch. 0 output pin (PPG00)
- P15/UO0/PPG20 pin
This pin has the following peripheral functions:
 - UART/SIO ch. 0 data output pin (UO0)
 - 8/16-bit PPG ch. 2 output pin (PPG20)

- Block diagram of P10/PPG10/CMP0_O, P11/PPG11, P13/PPG00 and P15/UO0/PPG20

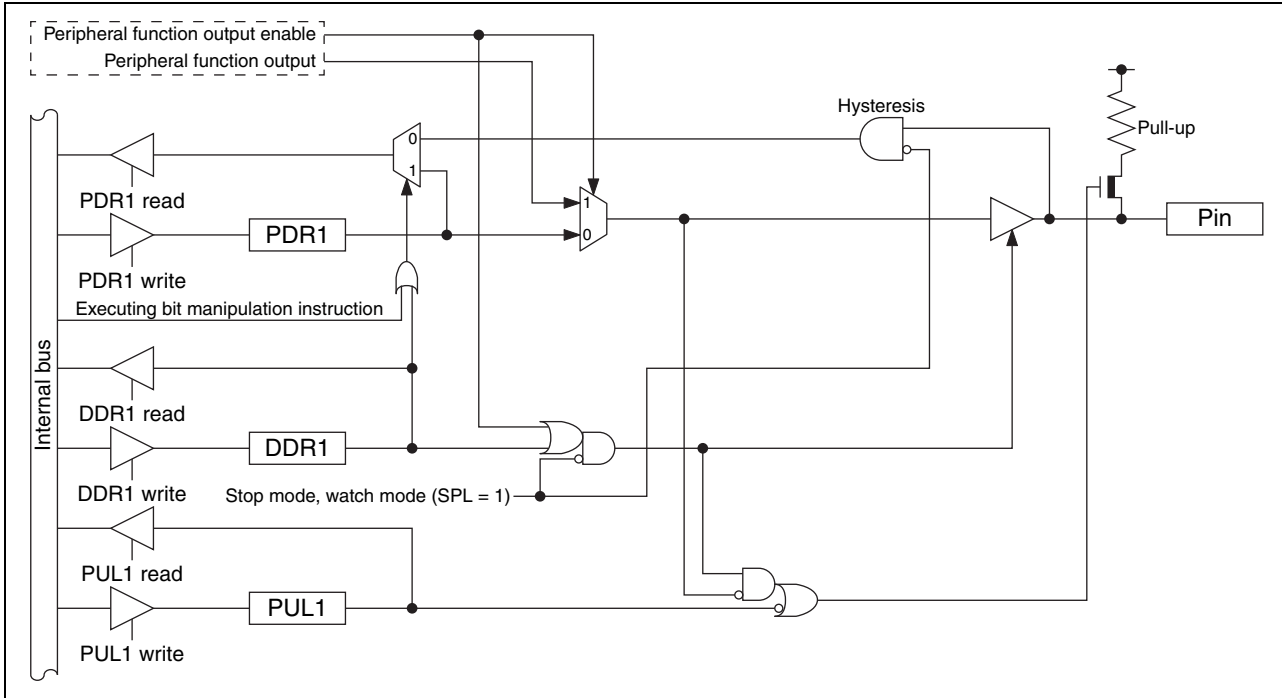

- P12/DBG/EC0 pin
 - This pin has the following peripheral functions:
 - DBG input pin (DBG)
 - 8/16-bit composite timer ch. 0 clock input pin (EC0)

• Block diagram of P12/DBG/EC0

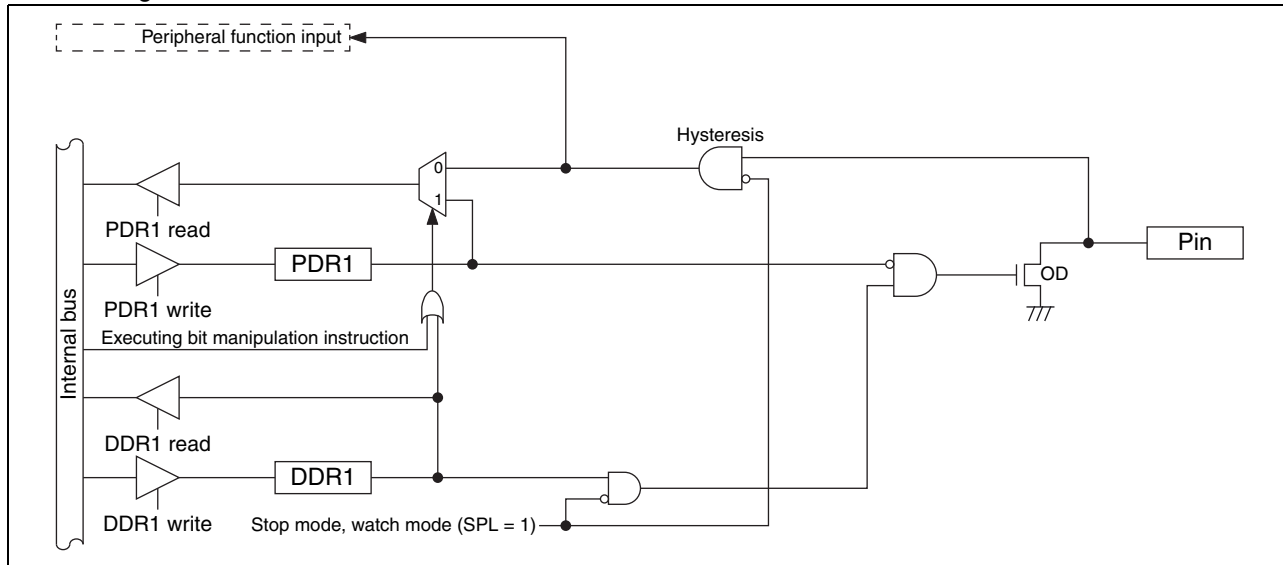

- P14/UCK0/PPG01 pin
 - This pin has the following peripheral functions:
 - UART/SIO ch. 0 clock I/O pin (UCK0)
 - 8/16-bit PPG ch. 0 output pin (PPG01)

• Block diagram of P14/UCK0/PPG01

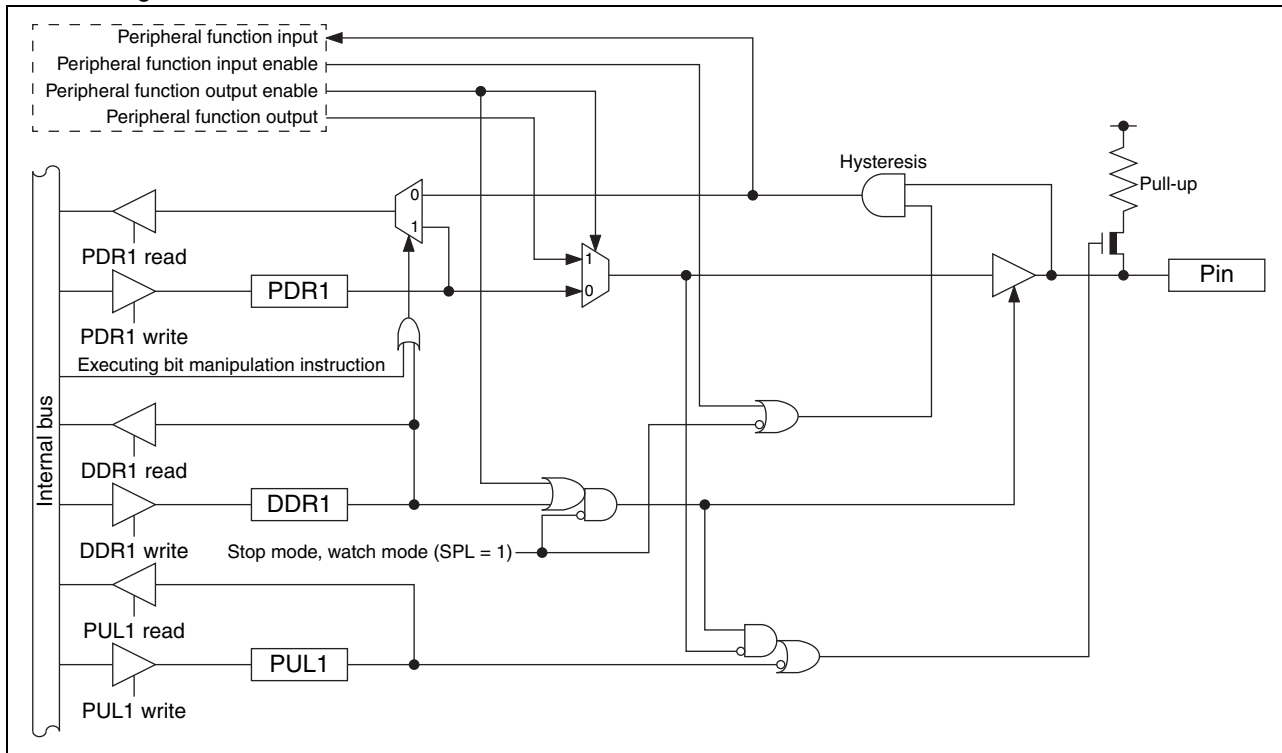

- P16/UI0/PPG21 pin
 - This pin has the following peripheral functions:
 - UART/SIO ch. 0 data input pin (UI0)
 - 8/16-bit PPG ch. 2 output pin (PPG21)

- Block diagram of P16/UI0/PPG21

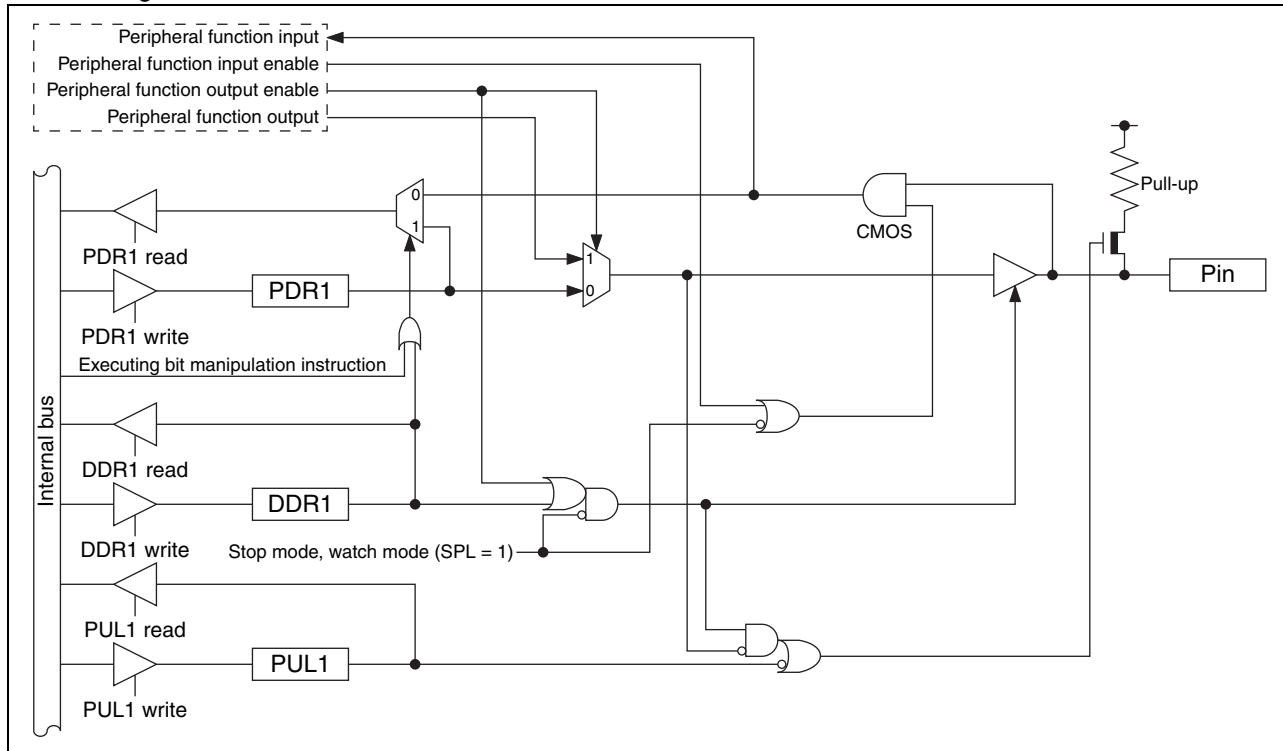

- P17/TO1/SNI0 pin
 - This pin has the following peripheral functions:
 - 16-bit reload timer ch. 1 output pin (TO1)
 - Trigger input pin for the position detection function of the MPG waveform sequencer (SNI0)

• Block diagram of P17/TO1/SNI0

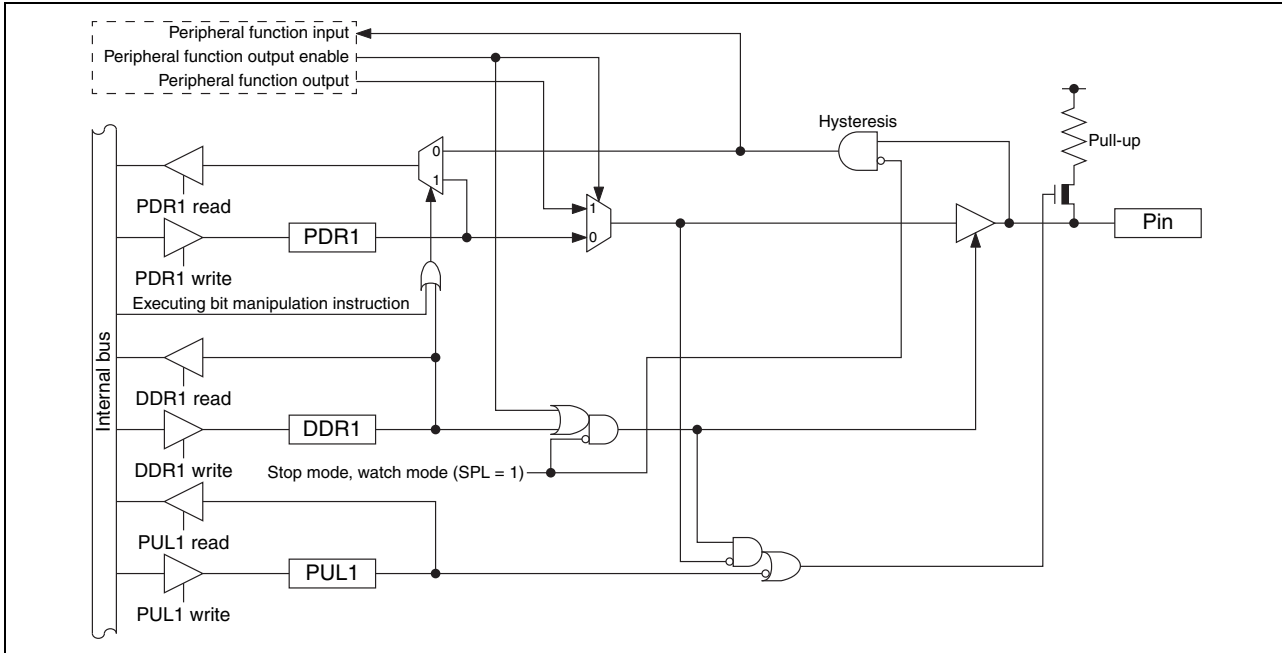

15.2.3 Port 1 registers

- Port 1 register functions

Register abbreviation	Data	Read	Read by read-modify-write (RMW) instruction	Write
PDR1	0	Pin state is “L” level.	PDR1 value is “0”.	As output port, outputs “L” level.
	1	Pin state is “H” level.	PDR1 value is “1”.	As output port, outputs “H” level.*
DDR1	0	Port input enabled		
	1	Port output enabled		
PUL1	0	Pull-up disabled		
	1	Pull-up enabled		

*: If the pin is an N-ch open drain pin, the pin state becomes Hi-Z.

- Correspondence between registers and pins for port 1

	Correspondence between related register bits and pins							
Pin name	P17	P16	P15	P14	P13	P12	P11	P10
PDR1	bit7	bit6	bit5	bit4	bit3	bit2*	bit1	bit0
DDR1								
PUL1								

*: Though P12 has no pull-up function, bit2 in the PUL1 register can still be accessed. The operation of P12 is not affected by the setting of bit2 in the PUL1 register.

15.2.4 Port 1 operations

- Operation as an output port
 - A pin becomes an output port if the bit in the DDR1 register corresponding to that pin is set to “1”.
 - For a pin shared with other peripheral functions, disable the output of such peripheral functions.
 - When a pin is used as an output port, it outputs the value of the PDR1 register to external pins.
 - If data is written to the PDR1 register, the value is stored in the output latch and is output to the pin set as an output port as it is.
 - Reading the PDR1 register returns the PDR1 register value.
- Operation as an input port
 - A pin becomes an input port if the bit in the DDR1 register corresponding to that pin is set to “0”.
 - For a pin shared with other peripheral functions, disable the output of such peripheral functions.
 - If data is written to the PDR1 register, the value is stored in the output latch but is not output to the pin set as an input port.
 - Reading the PDR1 register returns the pin value. However, if the read-modify-write (RMW) type of instruction is used to read the PDR1 register, the PDR1 register value is returned.
- Operation as a peripheral function output pin
 - A pin becomes a peripheral function output pin if the peripheral output function is enabled by setting the output enable bit of a peripheral function corresponding to that pin.
 - The pin value can be read from the PDR1 register even if the peripheral function output is enabled. Therefore, the output value of a peripheral function can be read by the read operation on the PDR1 register. However, if the read-modify-write (RMW) type of instruction is used to read the PDR1 register, the PDR1 register value is returned.
- Operation as a peripheral function input pin
 - To set a pin as an input port, set the bit in the DDR1 register corresponding to the input pin of a peripheral function

to “0”.

- Reading the PDR1 register returns the pin value, regardless of whether the peripheral function uses that pin as its input pin. However, if the read-modify-write (RMW) type of instruction is used to read the PDR1 register, the PDR1 register value is returned.
- Operation at reset
If the CPU is reset, all bits in the DDR1 register are initialized to “0” and port input is enabled.
- Operation in stop mode and watch mode
 - If the pin state setting bit in the standby control register (STBC:SPL) is set to “1” and the device transits to stop mode or watch mode, the pin is compulsorily made to enter the high impedance state regardless of the DDR1 register value. The input of that pin is locked to “L” level and blocked in order to prevent leaks due to input open. However, if the interrupt input of P14/UCK0 and P16/UI0 is enabled by the external interrupt control register ch. 0 (EIC00) of the external interrupt circuit and the interrupt pin selection circuit control register (WICR) of the interrupt pin selection circuit, the input is enabled and is not blocked.
 - If the pin state setting bit is “0”, the state of the port I/O or that of the peripheral function I/O remains unchanged and the output level is maintained.
- Operation of the pull-up register
Setting the bit in the PUL1 register to “1” makes the pull-up resistor be internally connected to the pin. When the pin output is “L” level, the pull-up resistor is disconnected regardless of the value of the PUL1 register.

15.3 Port 6

Port 6 is a general-purpose I/O port. This section focuses on its functions as a general-purpose I/O port. For details of peripheral functions, refer to their respective chapters in “New 8FX CY95630H Series Hardware Manual”.

15.3.1 Port 6 configuration

Port 6 is made up of the following elements.

- General-purpose I/O pins/peripheral function I/O pins
- Port 6 data register (PDR6)
- Port 6 direction register (DDR6)
- Port 6 pull-up register (PUL6)

15.3.2 Block diagrams of port 6

• P60/INT08/SDA/DTTI pin

This pin has the following peripheral functions:

- External interrupt circuit input pin (INT08)
- I²C bus interface ch. 0 data I/O pin (SDA)
- MPG waveform sequencer input pin (DTTI)

• P61/INT09/SCL/TI1 pin

This pin has the following peripheral functions:

- External interrupt circuit input pin (INT09)
- I²C bus interface ch. 0 clock I/O pin (SCL)
- 16-bit reload timer ch. 1 input pin (TI1)

- Block diagram of P60/INT08/SDA/DTTI and P61/INT09/SCL/TI1

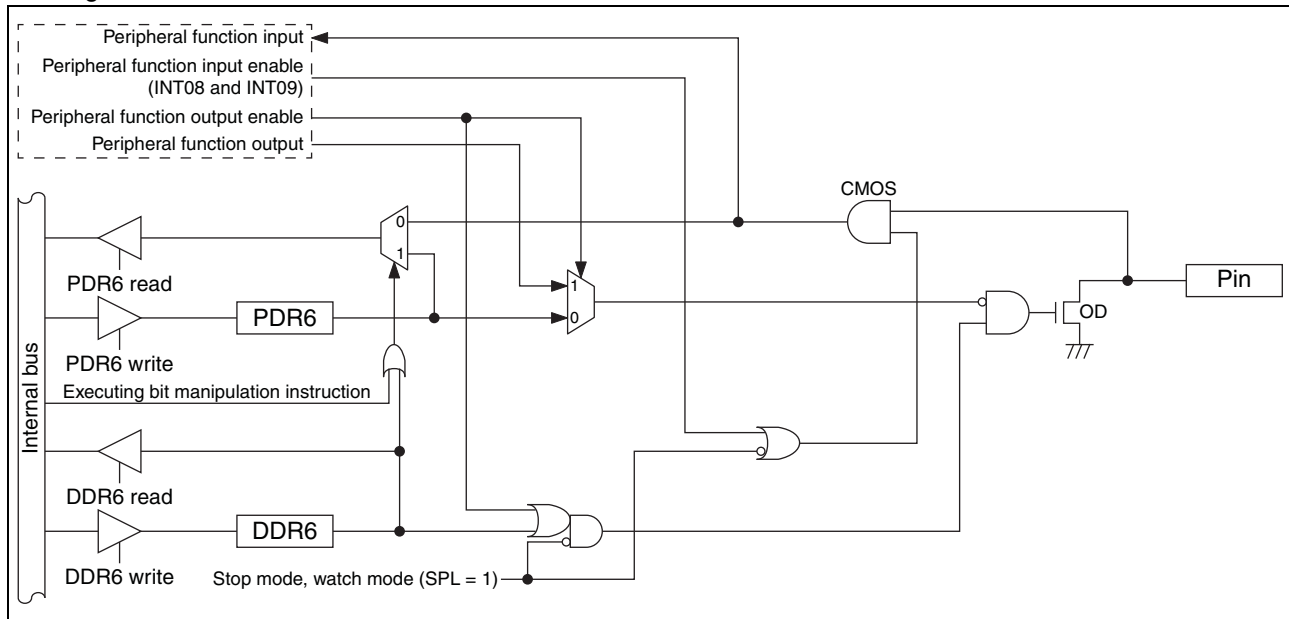

- P62/TO10/PPG00/OPT0 pin
This pin has the following peripheral functions:
 - 8/16-bit composite timer ch. 1 output pin (TO10)
 - 8/16-bit PPG ch. 0 output pin (PPG00)
 - MPG waveform sequencer output pin (OPT0)
- P63/TO11/PPG01/OPT1 pin
This pin has the following peripheral functions:
 - 8/16-bit composite timer ch. 1 output pin (TO11)
 - 8/16-bit PPG ch. 0 output pin (PPG01)
 - MPG waveform sequencer output pin (OPT1)
- P65/PPG11/OPT3 pin
This pin has the following peripheral functions:
 - 8/16-bit PPG ch. 1 output pin (PPG11)
 - MPG waveform sequencer output pin (OPT3)
- P66/PPG20/PPG1/OPT4 pin
This pin has the following peripheral functions:
 - 8/16-bit PPG ch. 2 output pin (PPG20)
 - 16-bit PPG timer ch. 1 output pin (PPG1)
 - MPG waveform sequencer output pin (OPT4)
- Block diagram of P62/TO10/PPG00/OPT0, P63/TO11/PPG01/OPT1, P65/PPG11/OPT3 and

P66/PPG20/PPG1/OPT4

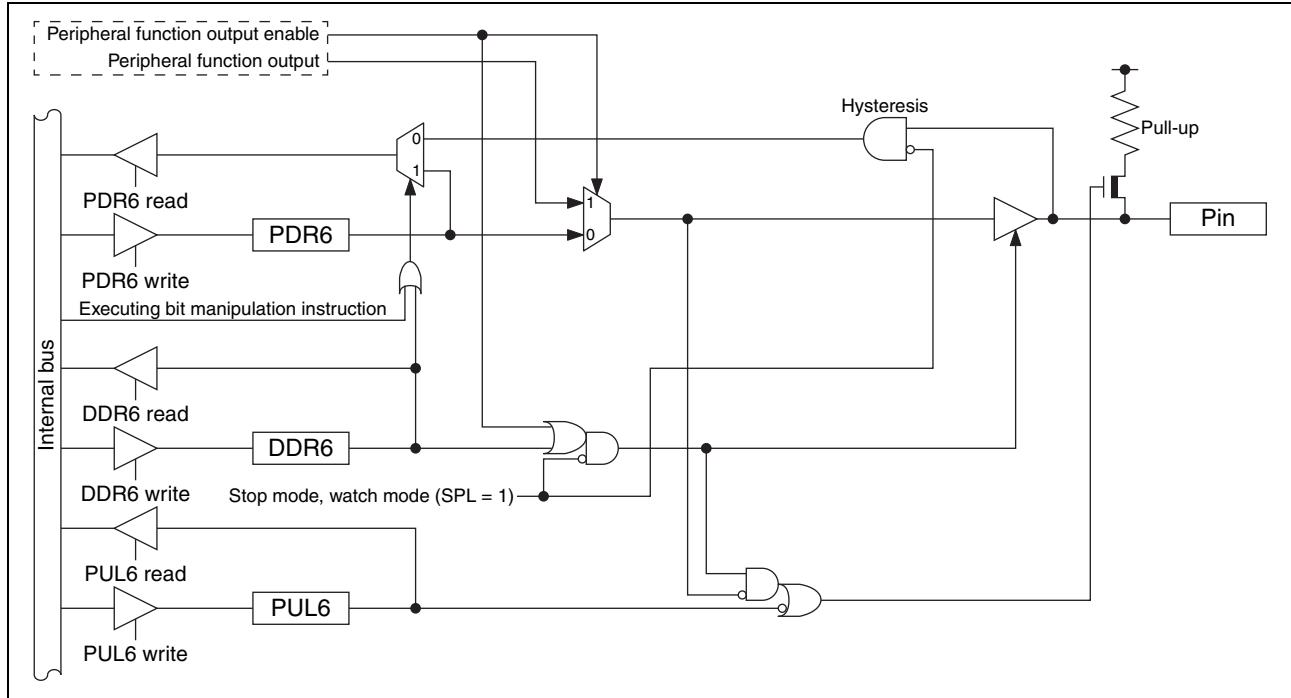

- P64/EC1/PPG10/OPT2 pin
This pin has the following peripheral functions:
 - 8/16-bit composite timer ch. 1 clock input pin (EC1)
 - 8/16-bit PPG ch. 1 output pin (PPG10)
 - MPG waveform sequencer output pin (OPT2)

- P67/PPG21/TRG1/OPT5 pin
This pin has the following peripheral functions:
 - 8/16-bit PPG ch. 2 output pin (PPG21)
 - 16-bit PPG timer ch. 1 trigger input pin (TRG1)
 - MPG waveform sequencer output pin (OPT5)

- Block diagram of P64/EC1/PPG10/OPT2 and P67/PPG21/TRG1/OPT5

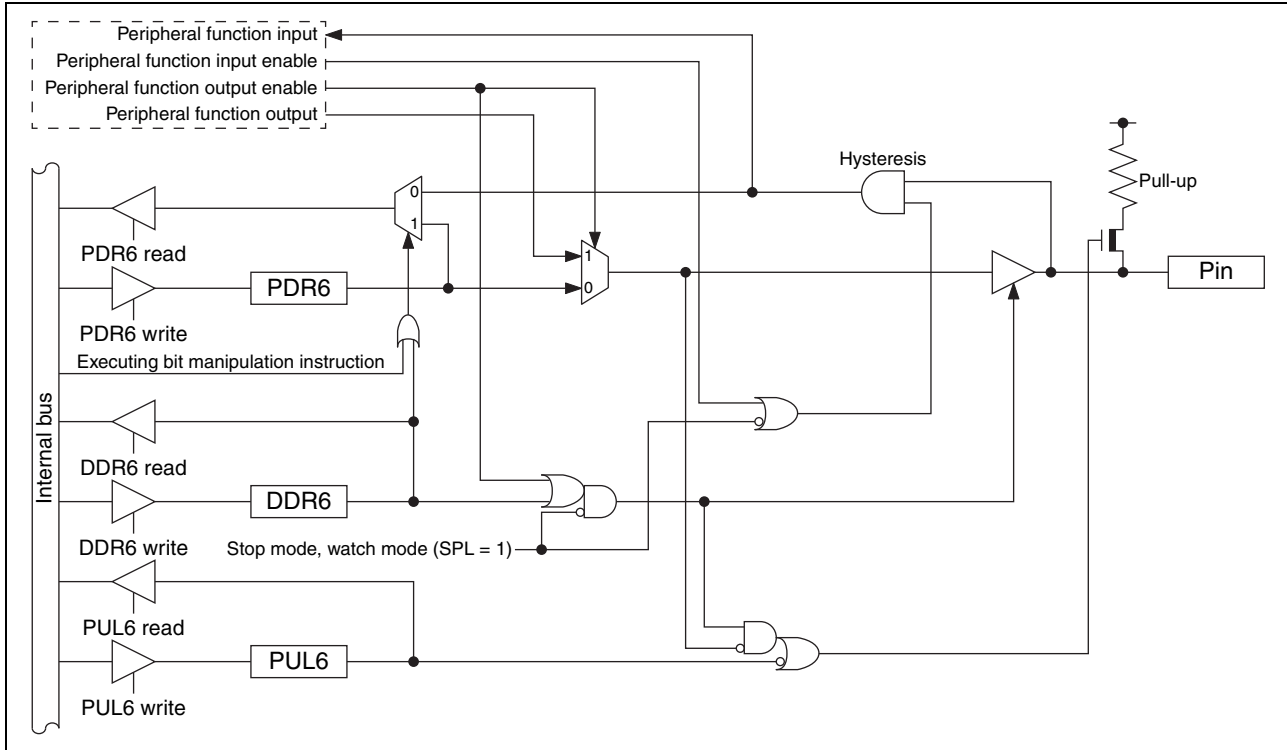

15.3.3 Port 6 registers

- Port 6 register functions

Register abbreviation	Data	Read	Read by read-modify-write (RMW) instruction	Write
PDR6	0	Pin state is "L" level.	PDR6 value is "0".	As output port, outputs "L" level.
	1	Pin state is "H" level.	PDR6 value is "1".	As output port, outputs "H" level.*
DDR6	0	Port input enabled		
	1	Port output enabled		
PUL6	0	Pull-up disabled		
	1	Pull-up enabled		

*: If the pin is an N-ch open drain pin, the pin state becomes Hi-Z.

- Correspondence between registers and pins for port 6

Pin name	Correspondence between related register bits and pins							
	P67	P66	P65	P64	P63	P62	P61	P60
PDR6	bit7	bit6	bit5	bit4	bit3	bit2	bit1	bit0
DDR6								-
PUL6							-	

15.3.4 Port 6 operations

- Operation as an output port
 - A pin becomes an output port if the bit in the DDR6 register corresponding to that pin is set to “1”.
 - For a pin shared with other peripheral functions, disable the output of such peripheral functions.
 - When a pin is used as an output port, it outputs the value of the PDR6 register to external pins.
 - If data is written to the PDR6 register, the value is stored in the output latch and is output to the pin set as an output port as it is.
 - Reading the PDR6 register returns the PDR6 register value.

- Operation as an input port
 - A pin becomes an input port if the bit in the DDR6 register corresponding to that pin is set to “0”.
 - For a pin shared with other peripheral functions, disable the output of such peripheral functions.
 - If data is written to the PDR6 register, the value is stored in the output latch but is not output to the pin set as an input port.
 - Reading the PDR6 register returns the pin value. However, if the read-modify-write (RMW) type of instruction is used to read the PDR6 register, the PDR6 register value is returned.

- Operation as a peripheral function output pin
 - A pin becomes a peripheral function output pin if the peripheral output function is enabled by setting the output enable bit of a peripheral function corresponding to that pin.
 - The pin value can be read from the PDR6 register even if the peripheral function output is enabled. Therefore, the output value of a peripheral function can be read by the read operation on the PDR6 register. However, if the read-modify-write (RMW) type of instruction is used to read the PDR6 register, the PDR6 register value is returned.

- Operation as a peripheral function input pin
 - To set a pin as an input port, set the bit in the DDR6 register corresponding to the input pin of a peripheral function to “0”.
 - Reading the PDR6 register returns the pin value, regardless of whether the peripheral function uses that pin as its input pin. However, if the read-modify-write (RMW) type of instruction is used to read the PDR6 register, the PDR6 register value is returned.

- Operation at reset

If the CPU is reset, all bits in the DDR6 register are initialized to “0” and port input is enabled.

- Operation in stop mode and watch mode
 - If the pin state setting bit in the standby control register (STBC:SPL) is set to “1” and the device transits to stop mode or watch mode, the pin is compulsorily made to enter the high impedance state regardless of the DDR6 register value. The input of that pin is locked to “L” level and blocked in order to prevent leaks due to input open. However, if the interrupt input from the external interrupt (INT08, INT09) is enabled, or if the interrupt input of P64/EC1 and P67/TRG1 is enabled by the external interrupt control register ch. 0 (EIC00) of the external interrupt circuit and the interrupt pin selection circuit control register (WICR) of the interrupt pin selection circuit, the input is enabled and is not blocked.
 - If the pin state setting bit is “0”, the state of the port I/O or that of the peripheral function I/O remains unchanged and the output level is maintained.

- Operation of the pull-up register

Setting the bit in the PUL6 register to “1” makes the pull-up resistor be internally connected to the pin. When the pin output is “L” level, the pull-up resistor is disconnected regardless of the value of the PUL6 register.

15.4 Port F

Port F is a general-purpose I/O port. This section focuses on its functions as a general-purpose I/O port. For details of peripheral functions, refer to their respective chapters in “New 8FX CY95630H Series Hardware Manual”.

15.4.1 Port F configuration

Port F is made up of the following elements.

- General-purpose I/O pins/peripheral function I/O pins
- Port F data register (PDRF)
- Port F direction register (DDRF)

15.4.2 Block diagrams of port F

- PF0/X0 pin

This pin has the following peripheral function:

- Main clock input oscillation pin (X0)

- PF1/X1 pin

This pin has the following peripheral function:

- Main clock I/O oscillation pin (X1)

- Block diagram of PF0/X0 and PF1/X1

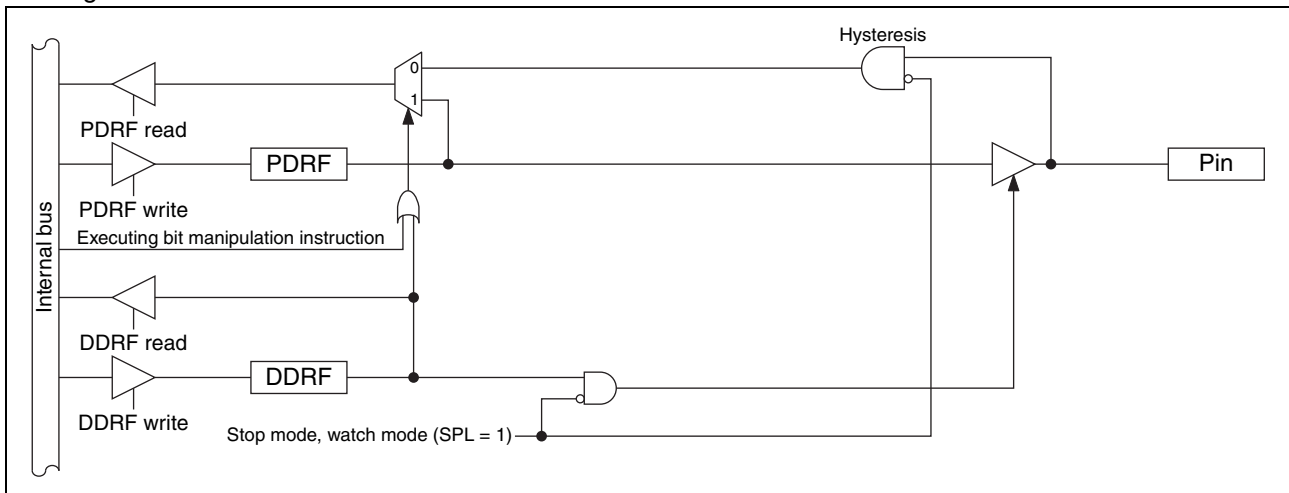

- PF2/ $\overline{\text{RST}}$ pin
 - This pin has the following peripheral function:
 - Reset pin ($\overline{\text{RST}}$)

• Block diagram of PF2/ $\overline{\text{RST}}$

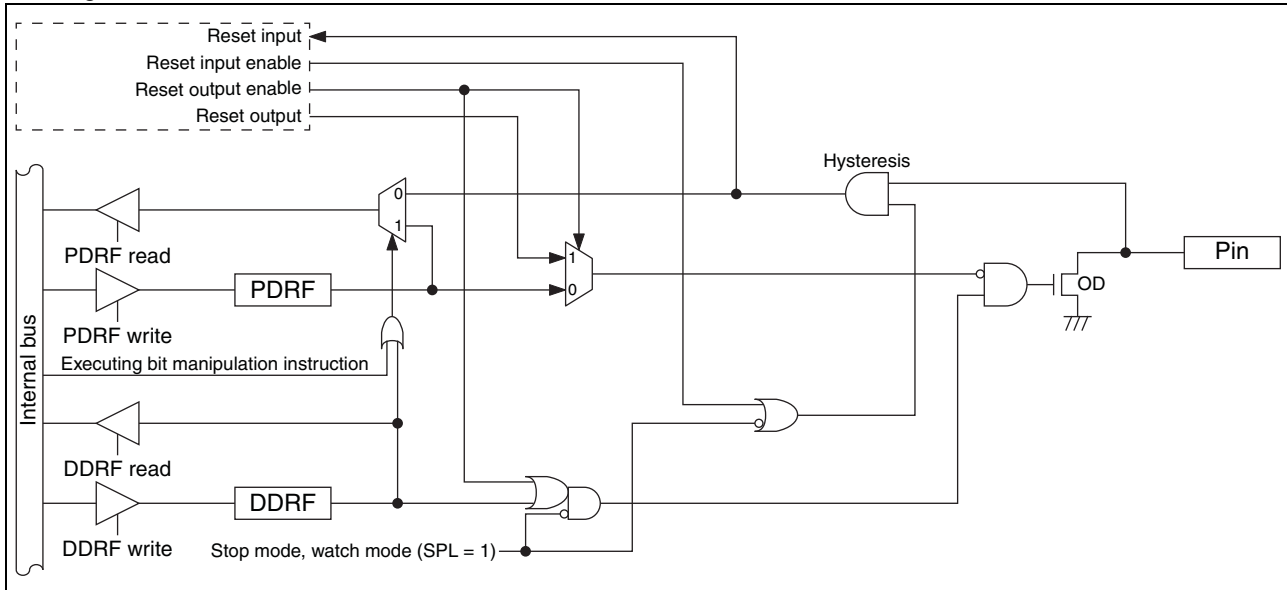

15.4.3 Port F registers

- Port F register functions

Register abbreviation	Data	Read	Read by read-modify-write (RMW) instruction	Write
PDRF	0	Pin state is "L" level.	PDRF value is "0".	As output port, outputs "L" level.
	1	Pin state is "H" level.	PDRF value is "1".	As output port, outputs "H" level.*
DDRF	0	Port input enabled		
	1	Port output enabled		

*: If the pin is an N-ch open drain pin, the pin state becomes Hi-Z.

- Correspondence between registers and pins for port F

Pin name	Correspondence between related register bits and pins							
	-	-	-	-	-	PF2*	PF1	PF0
PDRF	-	-	-	-	-	bit2	bit1	bit0
DDRF	-	-	-	-	-			

*: PF2/ $\overline{\text{RST}}$ is the dedicated reset pin on CY95F632H/F633H/F634H/F636H.

15.4.4 Port F operations

- Operation as an output port
 - A pin becomes an output port if the bit in the DDRF register corresponding to that pin is set to "1".
 - For a pin shared with other peripheral functions, disable the output of such peripheral functions.
 - When a pin is used as an output port, it outputs the value of the PDRF register to external pins.
 - If data is written to the PDRF register, the value is stored in the output latch and is output to the pin set as an output port as it is.
 - Reading the PDRF register returns the PDRF register value.

- Operation as an input port
 - A pin becomes an input port if the bit in the DDRF register corresponding to that pin is set to “0”.
 - For a pin shared with other peripheral functions, disable the output of such peripheral functions.
 - If data is written to the PDRF register, the value is stored in the output latch but is not output to the pin set as an input port.
 - Reading the PDRF register returns the pin value. However, if the read-modify-write (RMW) type of instruction is used to read the PDRF register, the PDRF register value is returned.
- Operation at reset

If the CPU is reset, all bits in the DDRF register are initialized to “0” and port input is enabled.
- Operation in stop mode and watch mode
 - If the pin state setting bit in the standby control register (STBC:SPL) is set to “1” and the device transits to stop mode or watch mode, the pin is compulsorily made to enter the high impedance state regardless of the DDRF register value. The input of that pin is locked to “L” level and blocked in order to prevent leaks due to input open.
 - If the pin state setting bit is “0”, the state of the port I/O or that of the peripheral function I/O remains unchanged and the output level is maintained.

15.5 Port G

Port G is a general-purpose I/O port. This section focuses on its functions as a general-purpose I/O port. For details of peripheral functions, refer to their respective chapters in “New 8FX CY95630H Series Hardware Manual”.

15.5.1 Port G configuration

Port G is made up of the following elements.

- General-purpose I/O pins/peripheral function I/O pins
- Port G data register (PDRG)
- Port G direction register (DDRG)
- Port G pull-up register (PULG)

15.5.2 Block diagram of port G

- PG1/X0A/SNI1 pin

This pin has the following peripheral functions:

- Subclock input oscillation pin (X0A)
- Trigger input pin for the position detection function of the MPG waveform sequencer (SNI1)

- PG2/X1A/SNI2 pin

This pin has the following peripheral functions:

- Subclock I/O oscillation pin (X1A)
- Trigger input pin for the position detection function of the MPG waveform sequencer (SNI2)

- Block diagram of PG1/X0A/SNI1 and PG2/X1A/SNI2

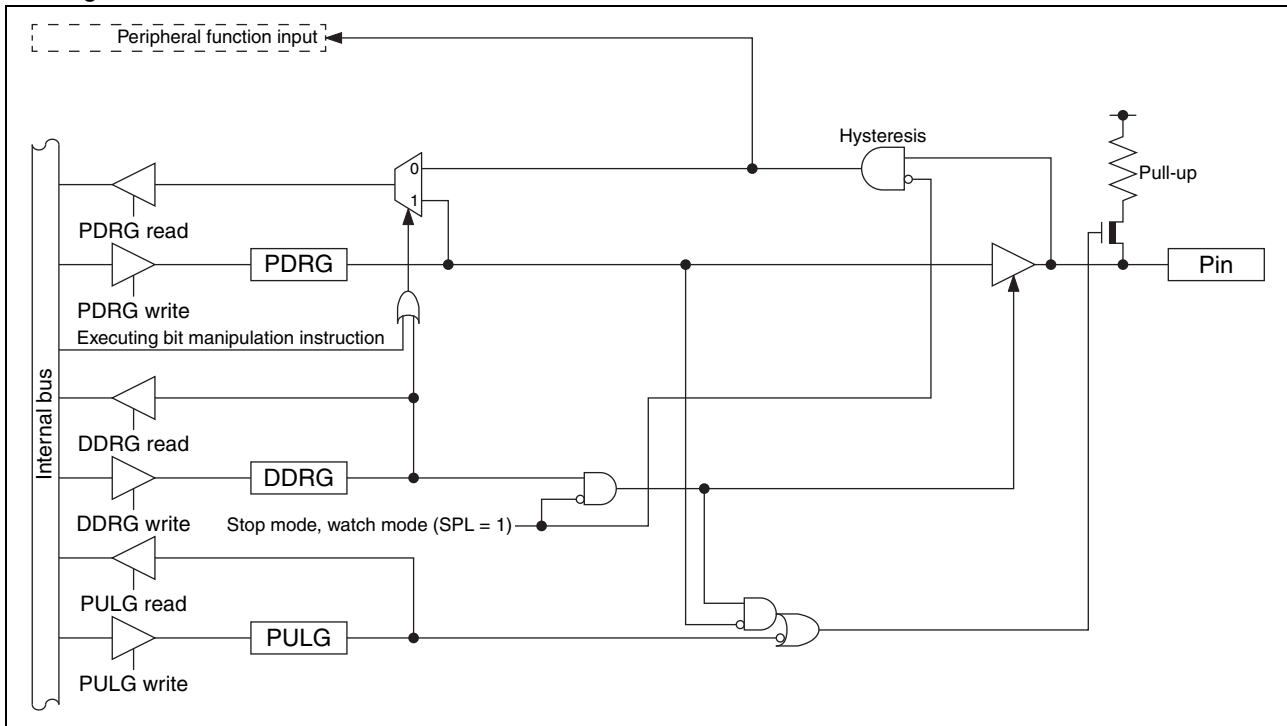

15.5.3 Port G registers

- Port G register functions

Register abbreviation	Data	Read	Read by read-modify-write (RMW) instruction	Write
PDRG	0	Pin state is "L" level.	PDRG value is "0".	As output port, outputs "L" level.
	1	Pin state is "H" level.	PDRG value is "1".	As output port, outputs "H" level.
DDRG	0	Port input enabled		
	1	Port output enabled		
PULG	0	Pull-up disabled		
	1	Pull-up enabled		

- Correspondence between registers and pins for port G

Pin name	Correspondence between related register bits and pins							
	-	-	-	-	-	PG2	PG1	-
PDRG								
DDRG	-	-	-	-	-	bit2	bit1	-
PULG								

15.5.4 Port G operations

- Operation as an output port
 - A pin becomes an output port if the bit in the DDRG register corresponding to that pin is set to "1".
 - For a pin shared with other peripheral functions, disable the output of such peripheral functions.
 - When a pin is used as an output port, it outputs the value of the PDRG register to external pins.

- If data is written to the PDRG register, the value is stored in the output latch and is output to the pin set as an output port as it is.
- Reading the PDRG register returns the PDRG register value.
- Operation as an input port
 - A pin becomes an input port if the bit in the DDRG register corresponding to that pin is set to “0”.
 - For a pin shared with other peripheral functions, disable the output of such peripheral functions.
 - If data is written to the PDRG register, the value is stored in the output latch but is not output to the pin set as an input port.
 - Reading the PDRG register returns the pin value. However, if the read-modify-write (RMW) type of instruction is used to read the PDRG register, the PDRG register value is returned.
- Operation as a peripheral function input pin
 - To set a pin as an input port, set the bit in the DDRG register corresponding to the input pin of a peripheral function to “0”.
 - Reading the PDRG register returns the pin value, regardless of whether the peripheral function uses that pin as its input pin. However, if the read-modify-write (RMW) type of instruction is used to read the PDRG register, the PDRG register value is returned.
- Operation at reset

If the CPU is reset, all bits in the DDRG register are initialized to “0” and port input is enabled.
- Operation in stop mode and watch mode
 - If the pin state setting bit in the standby control register (STBC:SPL) is set to “1” and the device transits to stop mode or watch mode, the pin is compulsorily made to enter the high impedance state regardless of the DDRG register value. The input of that pin is locked to “L” level and blocked in order to prevent leaks due to input open.
 - If the pin state setting bit is “0”, the state of the port I/O or that of the peripheral function I/O remains unchanged and the output level is maintained.
- Operation of the pull-up register

Setting the bit in the PULG register to “1” makes the pull-up resistor be internally connected to the pin. When the pin output is “L” level, the pull-up resistor is disconnected regardless of the value of the PULG register.

16. Interrupt Source Table

Interrupt source	Interrupt request number	Vector table address		Interrupt level setting register		Priority order of interrupt sources of the same level (occurring simultaneously)
		Upper	Lower	Register	Bit	
External interrupt ch. 0	IRQ00	0xFFFA	0xFFFB	ILR0	L00 [1:0]	<div style="display: flex; align-items: center; justify-content: center;"> <div style="margin-right: 10px;">High</div> </div> <div style="display: flex; align-items: center; justify-content: center; margin-top: 200px;"> <div style="margin-left: 10px;">Low</div> </div>
External interrupt ch. 4						
External interrupt ch. 1	IRQ01	0xFFE8	0xFFE9	ILR0	L01 [1:0]	
External interrupt ch. 5						
External interrupt ch. 2	IRQ02	0xFFE6	0xFFE7	ILR0	L02 [1:0]	
External interrupt ch. 6						
External interrupt ch. 3	IRQ03	0xFFE4	0xFFE5	ILR0	L03 [1:0]	
External interrupt ch. 7						
UART/SIO ch. 0	IRQ04	0xFFE2	0xFFE3	ILR1	L04 [1:0]	
MPG (DTTI)						
8/16-bit composite timer ch. 0 (lower)	IRQ05	0xFFE0	0xFFE1	ILR1	L05 [1:0]	
8/16-bit composite timer ch. 0 (upper)						
LIN-UART (reception)	IRQ07	0xFFEC	0xFFED	ILR1	L07 [1:0]	
LIN-UART (transmission)						
8/16-bit PPG ch. 1 (lower)	IRQ09	0xFFE8	0xFFE9	ILR2	L09 [1:0]	
8/16-bit PPG ch. 1 (upper)						
8/16-bit PPG ch. 2 (upper)	IRQ11	0xFFE4	0xFFE5	ILR2	L11 [1:0]	
8/16-bit PPG ch. 0 (upper)						
8/16-bit PPG ch. 0 (lower)	IRQ13	0xFFE0	0xFFE1	ILR3	L13 [1:0]	
8/16-bit composite timer ch. 1 (upper)						
8/16-bit PPG ch. 2 (lower)	IRQ15	0xFFDC	0xFFDD	ILR3	L15 [1:0]	
16-bit reload timer ch. 1						
MPG (write timing/compare clear)	IRQ16	0xFFDA	0xFFDB	ILR4	L16 [1:0]	
I ² C bus interface						
16-bit PPG timer ch. 1	IRQ17	0xFFD8	0xFFD9	ILR4	L17 [1:0]	
MPG (position detection/compare interrupt)						
8/10-bit A/D converter	IRQ18	0xFFD6	0xFFD7	ILR4	L18 [1:0]	
Time-base timer						
Watch prescaler	IRQ20	0xFFD2	0xFFD3	ILR5	L20 [1:0]	
Comparator						
External interrupt ch. 8	IRQ21	0xFFD0	0xFFD1	ILR5	L21 [1:0]	
External interrupt ch. 9						
8/16-bit composite timer ch. 1 (lower)	IRQ22	0xFFCE	0xFFCF	ILR5	L22 [1:0]	
Flash memory						
Flash memory	IRQ23	0xFFCC	0xFFCD	ILR5	L23 [1:0]	

17. Pin States In Each Mode

Pin name	Normal operation	Sleep mode	Stop mode		Watch mode		On reset
			SPL=0	SPL=1	SPL=0	SPL=1	
PF0/X0	Oscillation input	Oscillation input	Hi-Z	Hi-Z	Hi-Z	Hi-Z	—
	I/O port*4	I/O port*4	- Previous state kept - Input blocked*2*4	- Hi-Z - Input blocked*2*4	- Previous state kept - Input blocked*2*4	- Hi-Z - Input blocked*2*4	- Hi-Z - Input enabled*1 (However, it does not function.)
PF1/X1	Oscillation input	Oscillation input	Hi-Z	Hi-Z	Hi-Z	Hi-Z	—
	I/O port*4	I/O port*4	- Previous state kept - Input blocked*2*4	- Hi-Z - Input blocked*2*4	- Previous state kept - Input blocked*2*4	- Hi-Z - Input blocked*2*4	- Hi-Z - Input enabled*1 (However, it does not function.)
PG1/X0A/ SNI1	Oscillation input	Oscillation input	Hi-Z	Hi-Z	Hi-Z	Hi-Z	—
	I/O port*4/ peripheral function I/O	I/O port*4/ peripheral function I/O	- Previous state kept - Input blocked*2*4	- Hi-Z (However, the setting of the pull-up control is effective.) - Input blocked*2*4	- Previous state kept - Input blocked*2*4	- Hi-Z (However, the setting of the pull-up control is effective.) - Input blocked*2*4	- Hi-Z - Input enabled*1 (However, it does not function.)
PG2/X1A/ SNI2	Oscillation input	Oscillation input	Hi-Z	Hi-Z	Hi-Z	Hi-Z	—
	I/O port*4/ peripheral function I/O	I/O port*4/ peripheral function I/O	- Previous state kept - Input blocked*2*4	- Hi-Z (However, the setting of the pull-up control is effective.) - Input blocked*2*4	- Previous state kept - Input blocked*2*4	- Hi-Z (However, the setting of the pull-up control is effective.) - Input blocked*2*4	- Hi-Z - Input enabled*1 (However, it does not function.)
PF2/RST	I/O port	Reset input	Reset input	Reset input	Reset input	Reset input	Reset input*3
P60/INT08/ SDA/DTTI	I/O port/ peripheral function I/O	I/O port/ peripheral function I/O	- Previous state kept - Input blocked*2 (However, an external interrupt can be input when the external interrupt request is enabled.)	- Hi-Z - Input blocked*2 (However, an external interrupt can be input when the external interrupt request is enabled.)	- Previous state kept - Input blocked*2 (However, an external interrupt can be input when the external interrupt request is enabled.)	- Hi-Z - Input blocked*2 (However, an external interrupt can be input when the external interrupt request is enabled.)	- Hi-Z - Input enabled*1 (However, it does not function.)
P61/INT09/ SCL/TI1							
P62/TO10/ PPG00/ OPT0	I/O port/ peripheral function I/O	I/O port/ peripheral function I/O	- Previous state kept - Input blocked*2	- Hi-Z (However, the setting of the pull-up control is effective.) - Input blocked*2	- Previous state kept - Input blocked*2	- Hi-Z (However, the setting of the pull-up control is effective.) - Input blocked*2	- Hi-Z - Input enabled*1 (However, it does not function.)
P63/TO11/ PPG01/ OPT1							

Pin name	Normal operation	Sleep mode	Stop mode		Watch mode		On reset
			SPL=0	SPL=1	SPL=0	SPL=1	
P64/EC1/ PPG10/ OPT2	I/O port/ peripheral function I/O	I/O port/ peripheral function I/O	- Previous state kept - Input blocked*2 (However, an external interrupt can be input when the external interrupt request is enabled.)	- Hi-Z (However, the setting of the pull-up control is effective.) - Input blocked*2 (However, an external interrupt can be input when the external interrupt request is enabled.)	- Previous state kept - Input blocked*2 (However, an external interrupt can be input when the external interrupt request is enabled.)	- Hi-Z (However, the setting of the pull-up control is effective.) - Input blocked*2 (However, an external interrupt can be input when the external interrupt request is enabled.)	- Hi-Z - Input enabled*1 (However, it does not function.)
P65/PPG11/ OPT3 P66/PPG1/ PPG20/ OPT4	I/O port/ peripheral function I/O	I/O port/ peripheral function I/O	- Previous state kept - Input blocked*2	- Hi-Z (However, the setting of the pull-up control is effective.) - Input blocked*2	- Previous state kept - Input blocked*2	- Hi-Z (However, the setting of the pull-up control is effective.) - Input blocked*2	- Hi-Z - Input enabled*1 (However, it does not function.)
P67/TRG1/ PPG21/ OPT5	I/O port/ peripheral function I/O	I/O port/ peripheral function I/O	- Previous state kept - Input blocked*2 (However, an external interrupt can be input when the external interrupt request is enabled.)	- Hi-Z (However, the setting of the pull-up control is effective.) - Input blocked*2 (However, an external interrupt can be input when the external interrupt request is enabled.)	- Previous state kept - Input blocked*2 (However, an external interrupt can be input when the external interrupt request is enabled.)	- Hi-Z (However, the setting of the pull-up control is effective.) - Input blocked*2 (However, an external interrupt can be input when the external interrupt request is enabled.)	- Hi-Z - Input enabled*1 (However, it does not function.)
P10/PPG10/ CMP0_O P11/PPG11	I/O port/ peripheral function I/O	I/O port/ peripheral function I/O	- Previous state kept - Input blocked*2	- Hi-Z (However, the setting of the pull-up control is effective.) - Input blocked*2	- Previous state kept - Input blocked*2	- Hi-Z (However, the setting of the pull-up control is effective.) - Input blocked*2	- Hi-Z - Input enabled*1 (However, it does not function.)
P12/DBG/ EC0	I/O port/ peripheral function I/O	I/O port/ peripheral function I/O	- Previous state kept - Input blocked*2	- Hi-Z - Input blocked*2	- Previous state kept - Input blocked*2	- Hi-Z - Input blocked*2	- Hi-Z - Input enabled*1 (However, it does not function.)
P13/PPG00	I/O port/ peripheral function I/O	I/O port/ peripheral function I/O	- Previous state kept - Input blocked*2	- Hi-Z (However, the setting of the pull-up control is effective.) - Input blocked*2	- Previous state kept - Input blocked*2	- Hi-Z (However, the setting of the pull-up control is effective.) - Input blocked*2	- Hi-Z - Input enabled*1 (However, it does not function.)

Pin name	Normal operation	Sleep mode	Stop mode		Watch mode		On reset
			SPL=0	SPL=1	SPL=0	SPL=1	
P14/UCK0/ PPG01	I/O port/ peripheral function I/O	I/O port/ peripheral function I/O	- Previous state kept - Input blocked*2 (However, an external interrupt can be input when the external interrupt request is enabled.)	- Hi-Z (However, the setting of the pull-up control is effective.) - Input blocked*2 (However, an external interrupt can be input when the external interrupt request is enabled.)	- Previous state kept - Input blocked*2 (However, an external interrupt can be input when the external interrupt request is enabled.)	- Hi-Z (However, the setting of the pull-up control is effective.) - Input blocked*2 (However, an external interrupt can be input when the external interrupt request is enabled.)	- Hi-Z - Input enabled*1 (However, it does not function.)
P15/UO0/ PPG20	I/O port/ peripheral function I/O	I/O port/ peripheral function I/O	- Previous state kept - Input blocked*2	- Hi-Z (However, the setting of the pull-up control is effective.) - Input blocked*2	- Previous state kept - Input blocked*2	- Hi-Z (However, the setting of the pull-up control is effective.) - Input blocked*2	- Hi-Z - Input enabled*1 (However, it does not function.)
P16/UI0/ PPG21	I/O port/ peripheral function I/O	I/O port/ peripheral function I/O	- Previous state kept - Input blocked*2 (However, an external interrupt can be input when the external interrupt request is enabled.)	- Hi-Z (However, the setting of the pull-up control is effective.) - Input blocked*2 (However, an external interrupt can be input when the external interrupt request is enabled.)	- Previous state kept - Input blocked*2 (However, an external interrupt can be input when the external interrupt request is enabled.)	- Hi-Z (However, the setting of the pull-up control is effective.) - Input blocked*2 (However, an external interrupt can be input when the external interrupt request is enabled.)	- Hi-Z - Input enabled*1 (However, it does not function.)
P17/TO1/ SNI0	I/O port/ peripheral function I/O	I/O port/ peripheral function I/O	- Previous state kept - Input blocked*2	- Hi-Z (However, the setting of the pull-up control is effective.) - Input blocked*2	- Previous state kept - Input blocked*2	- Hi-Z (However, the setting of the pull-up control is effective.) - Input blocked*2	- Hi-Z - Input enabled*1 (However, it does not function.)
P00/INT00/ AN00/ CMP0_P	I/O port/ peripheral function I/O/ analog input	I/O port/ peripheral function I/O/ analog input	- Previous state kept	- Hi-Z (However, the setting of the pull-up control is effective.)	- Previous state kept	- Hi-Z (However, the setting of the pull-up control is effective.)	- Hi-Z - Input blocked*2
P01/INT01/ AN01/ CMP0_N			- Input blocked*2 (However, an external interrupt can be input when the external interrupt request is enabled.)	- Input blocked*2 (However, an external interrupt can be input when the external interrupt request is enabled.)	- Input blocked*2 (However, an external interrupt can be input when the external interrupt request is enabled.)	- Input blocked*2 (However, an external interrupt can be input when the external interrupt request is enabled.)	
P02/INT02/ AN02/SCK							
P03/INT03/ AN03/SOT							

Pin name	Normal operation	Sleep mode	Stop mode		Watch mode		On reset
			SPL=0	SPL=1	SPL=0	SPL=1	
P04/INT04/ AN04/SIN/ EC0	I/O port/ peripheral function I/O/ analog input	I/O port/ peripheral function I/O/ analog input	- Previous state kept - Input blocked*2 (However, an external interrupt can be input when the external interrupt request is enabled.)	- Hi-Z (However, the setting of the pull-up control is effective.) - Input blocked*2 (However, an external interrupt can be input when the external interrupt request is enabled.)	- Previous state kept - Input blocked*2 (However, an external interrupt can be input when the external interrupt request is enabled.)	- Hi-Z (However, the setting of the pull-up control is effective.) - Input blocked*2 (However, an external interrupt can be input when the external interrupt request is enabled.)	- Hi-Z - Input blocked*2
P05/INT05/ AN05/TO00							
P06/INT06/ AN06/TO01							
P07/INT07/ AN07							

SPL: Pin state setting bit in the standby control register (STBC:SPL)

Hi-Z: High impedance

*1: "Input enabled" means that the input function is enabled. While the input function is enabled, a pull-up or pull-down operation has to be performed in order to prevent leaks due to external input. If a pin is used as an output port, its pin state is the same as that of other ports.

*2: "Input blocked" means direct input gate operation from the pin is disabled.

*3: The PF2/RST pin stays at the state shown when configured as a reset pin.

*4: The pin stays at the state shown when configured as a general-purpose I/O port.

18. Electrical Characteristics

18.1 Absolute Maximum Ratings

Parameter	Symbol	Rating		Unit	Remarks
		Min	Max		
Power supply voltage*1	V _{CC}	V _{SS} – 0.3	V _{SS} + 6	V	
Input voltage*1	V _I	V _{SS} – 0.3	V _{SS} + 6	V	*2
Output voltage*1	V _O	V _{SS} – 0.3	V _{SS} + 6	V	*2
Maximum clamp current	I _{CLAMP}	–2	+2	mA	Applicable to specific pins*3
Total maximum clamp current	∑ I _{CLAMP}	—	20	mA	Applicable to specific pins*3
“L” level maximum output current	I _{OL}	—	15	mA	
“L” level average current	I _{OLAV1}	—	4	mA	Other than P62 to P67 Average output current = operating current × operating ratio (1 pin)
	I _{OLAV2}		12		P62 to P67 Average output current = operating current × operating ratio (1 pin)
“L” level total maximum output current	∑I _{OL}	—	100	mA	
“L” level total average output current	∑I _{OLAV}	—	37	mA	Total average output current = operating current × operating ratio (Total number of pins)
“H” level maximum output current	I _{OH}	—	–15	mA	
“H” level average current	I _{OHAV1}	—	–4	mA	Other than P62 to P67 Average output current = operating current × operating ratio (1 pin)
	I _{OHAV2}		–8		P62 to P67 Average output current = operating current × operating ratio (1 pin)
“H” level total maximum output current	∑I _{OH}	—	–100	mA	
“H” level total average output current	∑I _{OHAV}	—	–47	mA	Total average output current = operating current × operating ratio (Total number of pins)
Power consumption	P _d	—	320	mW	
Operating temperature	T _A	–40	+85	°C	
Storage temperature	T _{stg}	–55	+150	°C	

*1: These parameters are based on the condition that V_{SS} is 0.0 V.

*2: V_I and V_O must not exceed V_{CC} + 0.3 V. V_I must not exceed the rated voltage. However, if the maximum current to/from an input is limited by means of an external component, the I_{CLAMP} rating is used instead of the V_I rating.

*3: Specific pins: P00 to P07, P10, P11, P13 to P17, P62 to P67, PF0, PF1, PG1, PG2

- Use under recommended operating conditions.
- Use with DC voltage (current).
- The HV (High Voltage) signal is an input signal exceeding the V_{CC} voltage. Always connect a limiting resistor between the HV (High Voltage) signal and the microcontroller before applying the HV (High Voltage) signal.
- The value of the limiting resistor should be set to a value at which the current to be input to the microcontroller pin when the HV (High Voltage) signal is input is below the standard value, irrespective of whether the current is transient current or stationary current.
- When the microcontroller drive current is low, such as in low power consumption modes, the HV (High Voltage) input potential may pass through the protective diode to increase the potential of the V_{CC} pin, affecting other devices.
- If the HV (High Voltage) signal is input when the microcontroller power supply is off (not fixed at 0 V), since power is supplied from the pins, incomplete operations may be executed.
- If the HV (High Voltage) input is input after power-on, since power is supplied from the pins, the voltage of power supply may not be sufficient to enable a power-on reset.
- Do not leave the HV (High Voltage) input pin unconnected.
- Example of a recommended circuit:

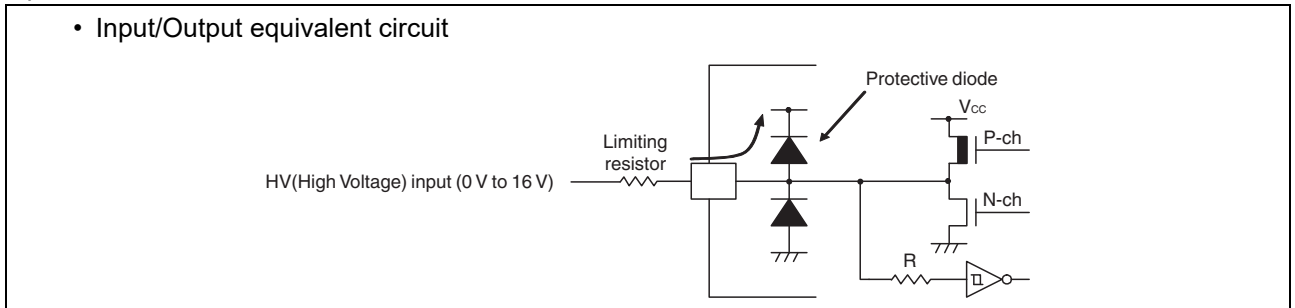

WARNING: Semiconductor devices may be permanently damaged by application of stress (including, without limitation, voltage, current or temperature) in excess of absolute maximum ratings. Do not exceed any of these ratings.

18.2 Recommended Operating Conditions

(V_{SS} = 0.0 V)

Parameter	Symbol	Value		Unit	Remarks
		Min	Max		
Power supply voltage	V _{CC}	2.4*1	5.5	V	In normal operation
		2.3	5.5		Hold condition in stop mode
Decoupling capacitor	C _s	0.022	1	μF	*2
Operating temperature	T _A	- 40	+85	°C	Other than on-chip debug mode
		+5	+35		On-chip debug mode

*1: The minimum power supply voltage becomes 2.88 V when a product with the low-voltage detection reset is used or when the on-chip debug mode is used.

*2: Use a ceramic capacitor or a capacitor with equivalent frequency characteristics. The decoupling capacitor for the V_{CC} pin must have a capacitance equal to or larger than the capacitance of C_s. For the connection to a decoupling capacitor C_s, see the diagram below. To prevent the device from unintentionally entering an unknown mode due to noise, minimize the distance between the C pin and C_s and the distance between C_s and the V_{SS} pin when designing the layout of a printed circuit board.

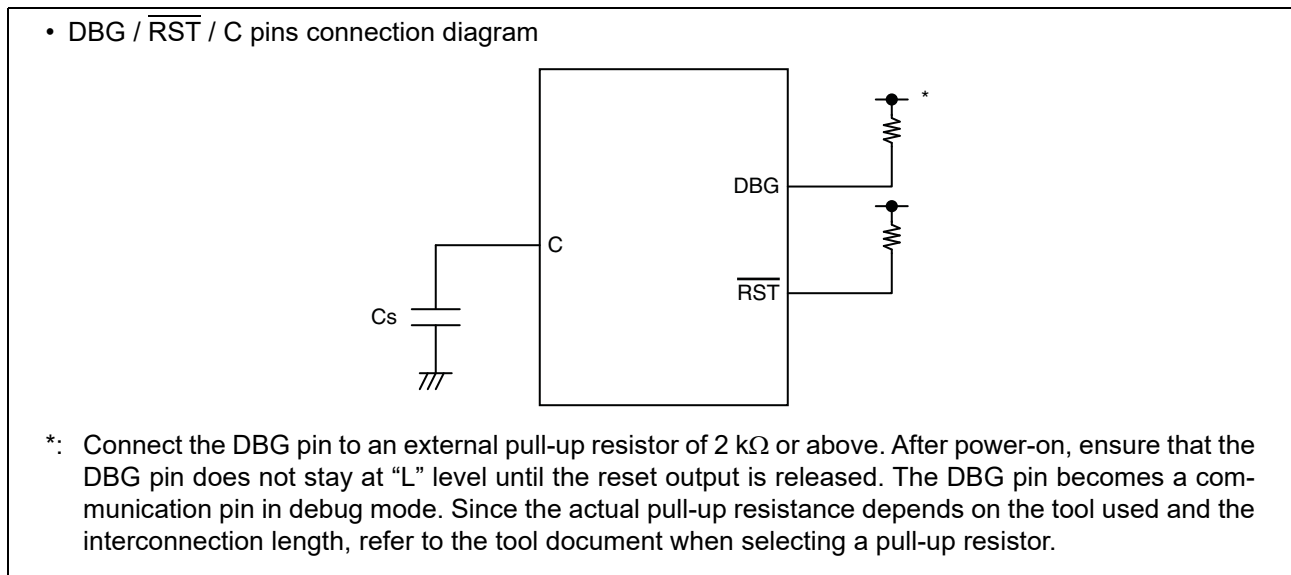

WARNING: The recommended operating conditions are required in order to ensure the normal operation of the semiconductor device. All of the device's electrical characteristics are warranted when the device is operated under these conditions.

Any use of semiconductor devices will be under their recommended operating condition. Operation under any conditions other than these conditions may adversely affect reliability of device and could result in device failure.

No warranty is made with respect to any use, operating conditions or combinations not represented on this data sheet. If you are considering application under any conditions other than listed herein, please contact sales representatives beforehand.

18.3 DC Characteristics
 $(V_{CC} = 5.0 V \pm 10\%, V_{SS} = 0.0 V, T_A = -40\text{ }^\circ\text{C to } +85\text{ }^\circ\text{C})$

Parameter	Symbol	Pin name	Condition	Value			Unit	Remarks
				Min	Typ	Max		
“H” level input voltage	V_{IH1}	P04, P16, P60, P61	—	$0.7 V_{CC}$	—	$V_{CC} + 0.3$	V	CMOS input level
	V_{IHS}	P00 to P07, P10 to P17, P60 to P67, PF0, PF1, PG1, PG2	—	$0.8 V_{CC}$	—	$V_{CC} + 0.3$	V	Hysteresis input
	V_{IHM}	PF2	—	$0.8 V_{CC}$	—	$V_{CC} + 0.3$	V	Hysteresis input
“L” level input voltage	V_{IL1}	P04, P16, P60, P61	—	$V_{SS} - 0.3$	—	$0.3 V_{CC}$	V	CMOS input level
	V_{ILS}	P00 to P07, P10 to P17, P60 to P67, PF0, PF1, PG1, PG2	—	$V_{SS} - 0.3$	—	$0.2 V_{CC}$	V	Hysteresis input
	V_{ILM}	PF2	—	$V_{SS} - 0.3$	—	$0.2 V_{CC}$	V	Hysteresis input
Open-drain output application voltage	V_D	P12, P60, P61, PF2	—	$V_{SS} - 0.3$	—	$V_{SS} + 5.5$	V	
“H” level output voltage	V_{OH1}	Output pins other than P12, P62 to P67, PF2	$I_{OH} = -4\text{ mA}$	$V_{CC} - 0.5$	—	—	V	
	V_{OH2}	P62 to P67	$I_{OH} = -8\text{ mA}$	$V_{CC} - 0.5$	—	—	V	
“L” level output voltage	V_{OL1}	Output pins other than P62 to P67	$I_{OL} = 4\text{ mA}$	—	—	0.4	V	
	V_{OL2}	P62 to P67	$I_{OL} = 12\text{ mA}$	—	—	0.4	V	
Input leak current (Hi-Z output leak current)	I_{LI}	All input pins	$0.0\text{ V} < V_I < V_{CC}$	-5	—	+5	μA	When the internal pull-up resistor is disabled
Internal pull-up resistor	R_{PULL}	P00 to P07, P10, P11, P13 to P17, P62 to P67, PG1, PG2	$V_I = 0\text{ V}$	25	50	100	k Ω	When the internal pull-up resistor is enabled
Input capacitance	C_{IN}	Other than V_{CC} and V_{SS}	$f = 1\text{ MHz}$	—	5	15	pF	

(V_{CC} = 5.0 V±10%, V_{SS} = 0.0 V, T_A = -40 °C to +85 °C)

Parameter	Symbol	Pin name	Condition	Value			Unit	Remarks
				Min	Typ*1	Max*2		
Power supply current*3	I _{CC}	V _{CC} (External clock operation)	F _{CH} = 32 MHz F _{MP} = 16 MHz Main clock mode (divided by 2)	—	3.6	5.8	mA	Except during Flash memory programming and erasing
				—	7.5	13.8	mA	During Flash memory programming and erasing
				—	4.1	9.1	mA	At A/D conversion
	I _{CCS}	V _{CC} (External clock operation)	F _{CH} = 32 MHz F _{MP} = 16 MHz Main sleep mode (divided by 2)	—	1.3	3	mA	
	I _{CCCL}	V _{CC} (External clock operation)	F _{CL} = 32 kHz F _{MPL} = 16 kHz Subclock mode (divided by 2) T _A = +25°C	—	49	145	μA	
	I _{CCLS}	V _{CC} (External clock operation)	F _{CL} = 32 kHz F _{MPL} = 16 kHz Subsleep mode (divided by 2) T _A = +25°C	—	10	15	μA	In deep standby mode
	I _{CCCT}	V _{CC} (External clock operation)	F _{CL} = 32 kHz Watch mode Main stop mode T _A = +25°C	—	7	13	μA	In deep standby mode
	I _{CCMPLL}	V _{CC}	F _{MCRPLL} = 16 MHz F _{MP} = 16 MHz Main CR PLL clock mode (multiplied by 4) T _A = +25°C	—	4.7	6.8	mA	
	I _{CCMCR}		F _{CRH} = 4 MHz F _{MP} = 4 MHz Main CR clock mode	—	1.1	4.6	mA	
	I _{CCSCR}		Sub-CR clock mode (divided by 2) T _A = +25°C	—	58.1	230	μA	
	I _{CCTS}	V _{CC} (External clock operation)	F _{CH} = 32 MHz Time-base timer mode T _A = +25°C	—	345	395	μA	In deep standby mode
I _{CCCH}	V _{CC} (External clock operation)	Substop mode T _A = +25°C	—	6	10	μA	In deep standby mode	

($V_{CC} = 5.0\text{ V} \pm 10\%$, $V_{SS} = 0.0\text{ V}$, $T_A = -40\text{ }^\circ\text{C}$ to $+85\text{ }^\circ\text{C}$)

Parameter	Symbol	Pin name	Condition	Value			Unit	Remarks
				Min	Typ*1	Max*2		
Power supply current*3	I _v	V _{CC}	Current consumption of the comparator	—	60	160	μA	
	I _{LVD}		Current consumption of the low-voltage detection circuit	—	4	7	μA	
	I _{CRH}		Current consumption of the main CR oscillator	—	240	320	μA	
	I _{CRL}		Current consumption of the sub-CR oscillator oscillating at 100 kHz	—	7	20	μA	
	I _{INSTBY}		Current consumption difference between normal standby mode and deep standby mode T _A = +25°C	—	20	30	μA	

*1: $V_{CC} = 5.0\text{ V}$, $T_A = +25\text{ }^\circ\text{C}$

*2: $V_{CC} = 5.5\text{ V}$, $T_A = +85\text{ }^\circ\text{C}$ (unless otherwise specified)

*3: • The power supply current is determined by the external clock. When the low-voltage detection circuit is selected, the power supply current is the sum of adding the current consumption of the low-voltage detection circuit (I_{LVD}) to one of the values from I_{CC} to I_{CCH}. In addition, when both the low-voltage detection option and the CR oscillator are selected, the power supply current is the sum of adding up the current consumption of the low-voltage detection circuit (I_{LVD}), the current consumption of the CR oscillators (I_{CRH}, I_{CRL}) and a specified value. In on-chip debug mode, the CR oscillator (I_{CRH}) and the low-voltage detection circuit are always in operation, and current consumption therefore increases accordingly.

• See “4. AC Characteristics Clock Timing” for F_{CH}, F_{CL}, F_{CRH} and F_{MCRPLL}.

• See “4. AC Characteristics Source Clock/Machine Clock” for F_{MP} and F_{MPL}.

• The power supply current value in standby mode is measured in deep standby mode. The current consumption in normal standby is higher than that in deep standby mode. The power supply current value in normal standby can be found by adding the current consumption difference between normal standby mode and deep standby mode (I_{INSTBY}) to the power supply current value in deep standby mode. For details of normal standby and deep standby mode, refer to “CHAPTER 3 CLOCK CONTROLLER” in “New 8FX CY95630H Series Hardware Manual”.

18.4 AC Characteristics
18.4.1 Clock Timing

 (V_{CC} = 2.4 V to 5.5 V, V_{SS} = 0.0 V, T_A = -40°C to +85°C)

Parameter	Symbol	Pin name	Condition	Value			Unit	Remarks	
				Min	Typ	Max			
Clock frequency	F _{CH}	X0, X1	—	1	—	16.25	MHz	When the main oscillation circuit is used	
		X0	X1: open	1	—	12	MHz	When the main external clock is used	
		X0, X1	*	1	—	32.5	MHz	is used	
	F _{CRH}	—	—	—	3.92	4	4.08	MHz	Operating conditions • The main CR clock is used. • 0°C ≤ T _A ≤ +70°C
					3.8	4	4.2	MHz	Operating conditions • The main CR clock is used. • -40 °C ≤ T _A < 0 °C, +70 °C < T _A ≤ +85 °C
	F _{MCRPLL}	—	—	—	7.84	8	8.16	MHz	Operating conditions • PLL multiplication rate: 2 • 0°C ≤ T _A ≤ +70°C
					7.6	8	8.4	MHz	Operating conditions • PLL multiplication rate: 2 • -40 °C ≤ T _A < 0 °C, +70 °C < T _A ≤ +85 °C
					9.8	10	10.2	MHz	Operating conditions • PLL multiplication rate: 2.5 • 0°C ≤ T _A ≤ +70°C
					9.5	10	10.5	MHz	Operating conditions • PLL multiplication rate: 2.5 • -40 °C ≤ T _A < 0 °C, +70 °C < T _A ≤ +85 °C
					11.76	12	12.24	MHz	Operating conditions • PLL multiplication rate: 3 • 0°C ≤ T _A ≤ +70°C
					11.4	12	12.6	MHz	Operating conditions • PLL multiplication rate: 3 • -40 °C ≤ T _A < 0 °C, +70 °C < T _A ≤ +85 °C
					15.68	16	16.32	MHz	Operating conditions • PLL multiplication rate: 4 • 0°C ≤ T _A ≤ +70°C
					15.2	16	16.8	MHz	Operating conditions • PLL multiplication rate: 4 • -40 °C ≤ T _A < 0 °C, +70 °C < T _A ≤ +85 °C
	F _{CL}	X0A, X1A	—	—	—	32.768	—	kHz	When the suboscillation circuit is used
					—	32.768	—	kHz	When the sub-external clock is used
F _{CRL}	—	—	—	50	100	150	kHz	When the sub-CR clock is used	

($V_{CC} = 2.4\text{ V to }5.5\text{ V}$, $V_{SS} = 0.0\text{ V}$, $T_A = -40^\circ\text{C to }+85^\circ\text{C}$)

Parameter	Symbol	Pin name	Condition	Value			Unit	Remarks
				Min	Typ	Max		
Clock cycle time	t_{HCYL}	X0, X1	—	61.5	—	1000	ns	When the main oscillation circuit is used
		X0	X1: open	83.4	—	1000	ns	When an external clock is used
		X0, X1	*	30.8	—	1000	ns	
	t_{LCYL}	X0A, X1A	—	—	30.5	—	μs	When the subclock is used
Input clock pulse width	t_{WH1}, t_{WL1}	X0	X1: open	33.4	—	—	ns	When an external clock is used, the duty ratio should range between 40% and 60%.
		X0, X1	*	12.4	—	—	ns	
		t_{WH2}, t_{WL2}	X0A	—	—	15.2	—	
Input clock rising time and falling time	t_{CR}, t_{CF}	X0, X0A	X1: open	—	—	5	ns	When an external clock is used
		X0, X1, X0A, X1A	*	—	—	5	ns	
CR oscillation start time	t_{CRHWK}	—	—	—	—	50	μs	When the main CR clock is used
	t_{CRLWK}	—	—	—	—	30	μs	When the sub-CR clock is used
PLL oscillation start time	$t_{MCRPLLWK}$	—	—	—	—	100	μs	When the main CR PLL clock is used

*: The external clock signal is input to X0 and the inverted external clock signal to X1.

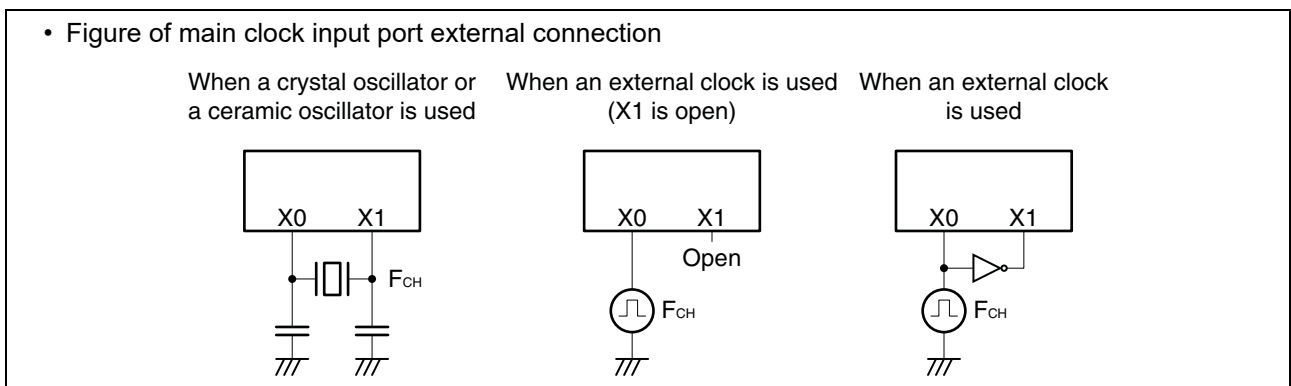
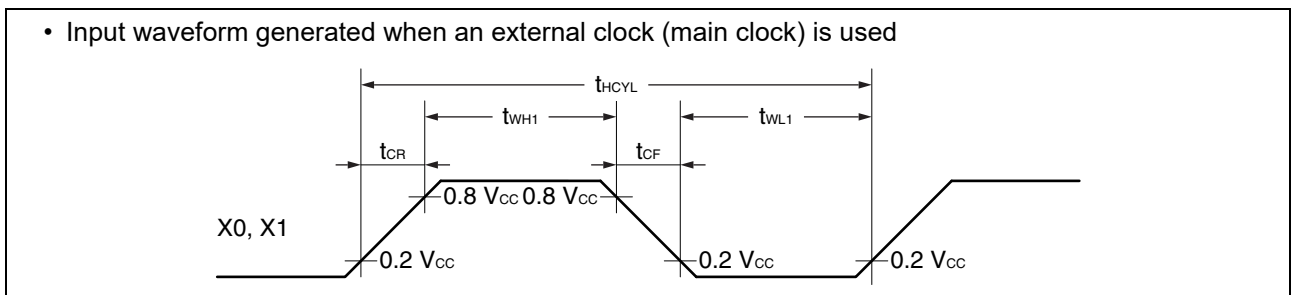

- Input waveform generated when an external clock (subclock) is used

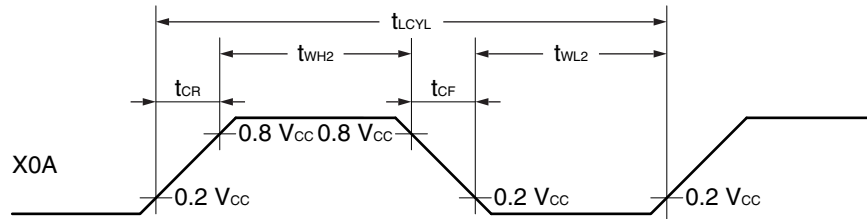

- Figure of subclock input port external connection

When a crystal oscillator or a ceramic oscillator is used

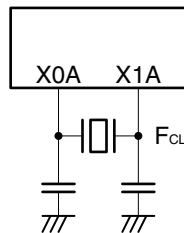

When an external clock is used

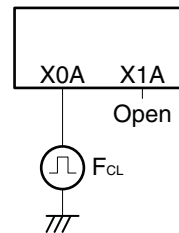

- Input waveform generated when an internal clock (main CR clock) is used

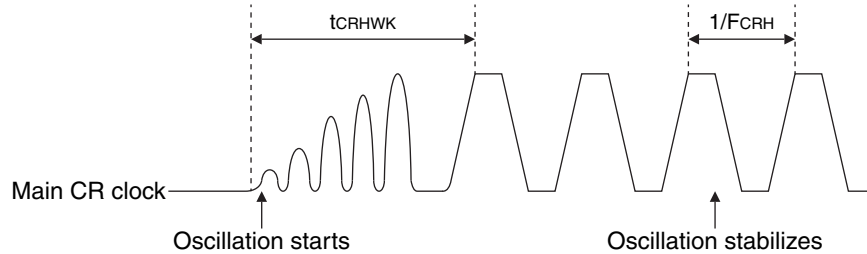

- Input waveform generated when an internal clock (sub-CR clock) is used

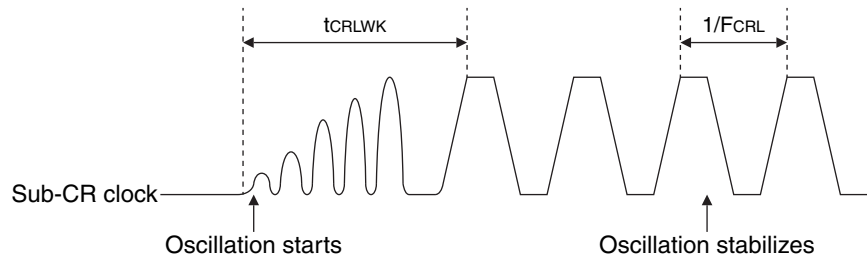

- Input waveform generated when an internal clock (main CR PLL clock) is used

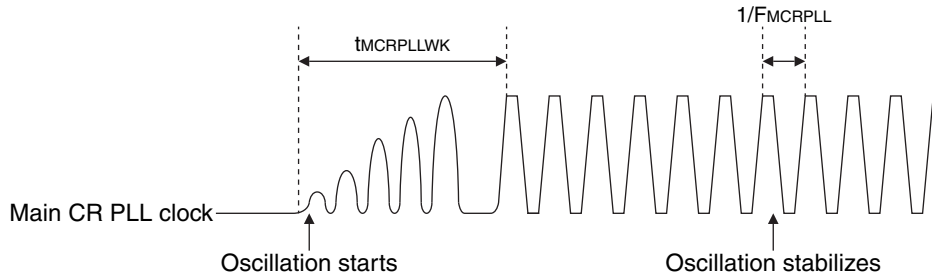

18.4.2 Source Clock/Machine Clock

($V_{CC} = 5.0 V \pm 10\%$, $V_{SS} = 0.0 V$, $T_A = -40^\circ C$ to $+85^\circ C$)

Parameter	Symbol	Pin name	Value			Unit	Remarks
			Min	Typ	Max		
Source clock cycle time*1	tSCLK	—	61.5	—	2000	ns	When the main external clock is used Min: $F_{CH} = 32.5$ MHz, divided by 2 Max: $F_{CH} = 1$ MHz, divided by 2
			62.5	—	250	ns	When the main CR clock is used Min: $F_{CRH} = 4$ MHz, multiplied by 4 Max: $F_{CRH} = 4$ MHz, no division
			—	61	—	μs	When the suboscillation clock is used $F_{CL} = 32.768$ kHz, divided by 2
			—	20	—	μs	When the sub-CR clock is used $F_{CL} = 100$ kHz, divided by 2
Source clock frequency	F _{SP}	—	0.5	—	16.25	MHz	When the main oscillation clock is used
			—	4	—	MHz	When the main CR clock is used
	F _{SPL}		—	16.384	—	kHz	When the suboscillation clock is used
			—	50	—	kHz	When the sub-CR clock is used $F_{CRL} = 100$ kHz, divided by 2
Machine clock cycle time*2 (minimum instruction execution time)	tMCLK	—	61.5	—	32000	ns	When the main oscillation clock is used Min: $F_{SP} = 16.25$ MHz, no division Max: $F_{SP} = 0.5$ MHz, divided by 16
			250	—	4000	ns	When the main CR clock is used Min: $F_{SP} = 4$ MHz, no division Max: $F_{SP} = 4$ MHz, divided by 16
			61	—	976.5	μs	When the suboscillation clock is used Min: $F_{SPL} = 16.384$ kHz, no division Max: $F_{SPL} = 16.384$ kHz, divided by 16
			20	—	320	μs	When the sub-CR clock is used Min: $F_{SPL} = 50$ kHz, no division Max: $F_{SPL} = 50$ kHz, divided by 16

Parameter	Symbol	Pin name	Value			Unit	Remarks
			Min	Typ	Max		
Machine clock frequency	F _{MP}	—	0.031	—	16.25	MHz	When the main oscillation clock is used
			0.25	—	16	MHz	When the main CR clock is used
	F _{MPL}		1.024	—	16.384	kHz	When the suboscillation clock is used
			3.125	—	50	kHz	When the sub-CR clock is used F _{CRL} = 100 kHz

*1: This is the clock before it is divided according to the division ratio set by the machine clock division ratio select bits (SYCC:DIV[1:0]). This source clock is divided to become a machine clock according to the division ratio set by the machine clock division ratio select bits (SYCC:DIV[1:0]). In addition, a source clock can be selected from the following.

- Main clock divided by 2
- Main CR clock
- PLL multiplication of main CR clock (Select a multiplication rate from 2, 2.5, 3 and 4.)
- Subclock divided by 2
- Sub-CR clock divided by 2

*2: This is the operating clock of the microcontroller. A machine clock can be selected from the following.

- Source clock (no division)
- Source clock divided by 4
- Source clock divided by 8
- Source clock divided by 16

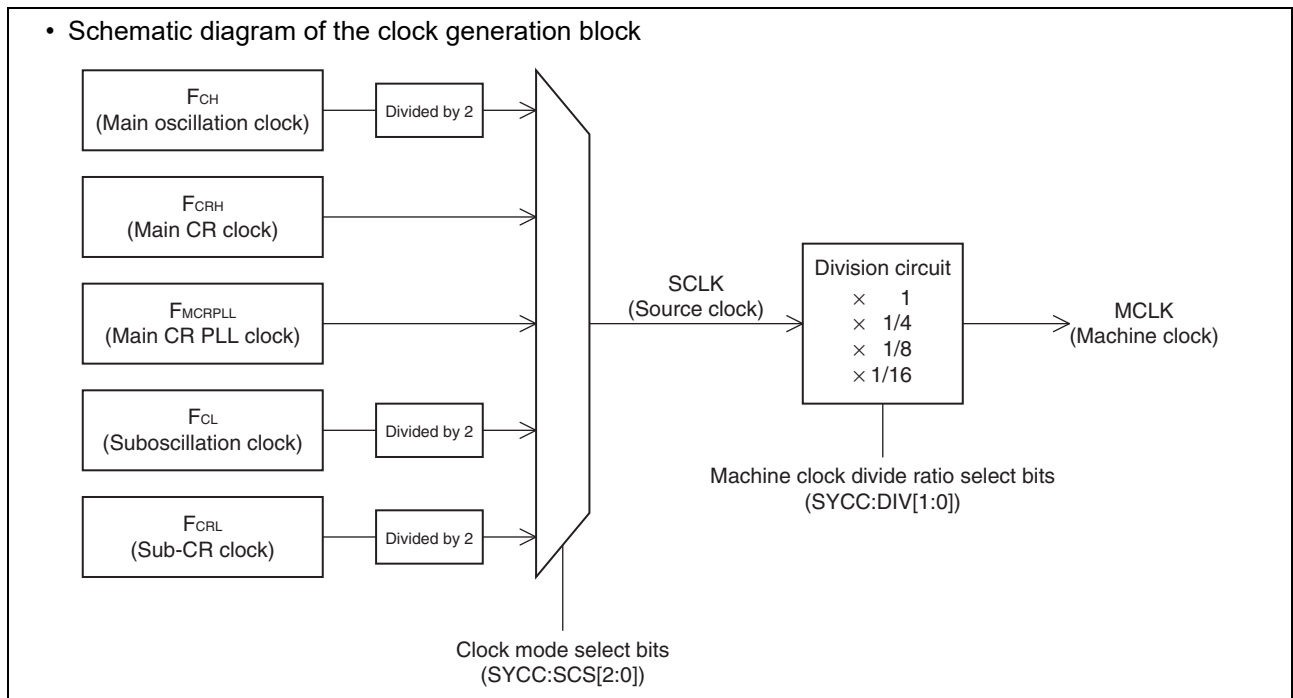

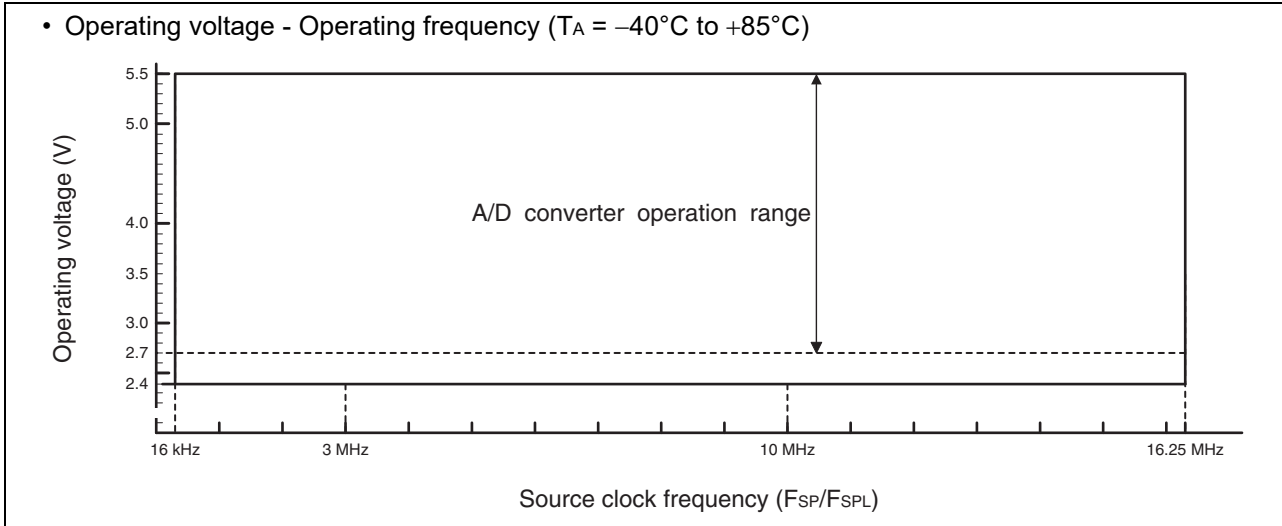

18.4.3 External Reset

($V_{CC} = 5.0\text{ V} \pm 10\%$, $V_{SS} = 0.0\text{ V}$, $T_A = -40^{\circ}\text{C}$ to $+85^{\circ}\text{C}$)

Parameter	Symbol	Value		Unit	Remarks
		Min	Max		
RST "L" level pulse width	t_{RSTL}	$2 t_{MCLK}^*$	—	ns	

*: See "Source Clock/Machine Clock" for t_{MCLK} .

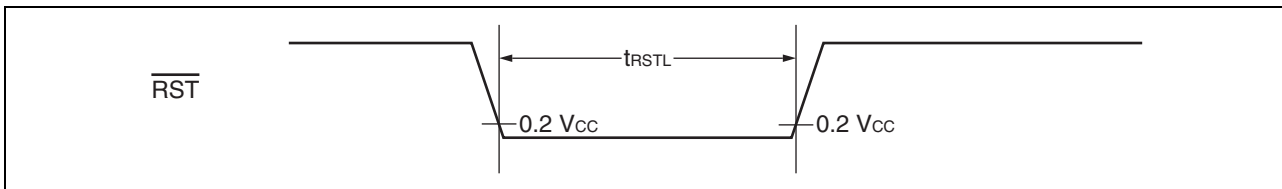

18.4.4 Power-on Reset

($V_{SS} = 0.0\text{ V}$, $T_A = -40^\circ\text{C}$ to $+85^\circ\text{C}$)

Parameter	Symbol	Condition	Value		Unit	Remarks
			Min	Max		
Power supply rising time	t_R	—	—	50	ms	
Power supply cutoff time	t_{OFF}	—	1	—	ms	Wait time until power-on

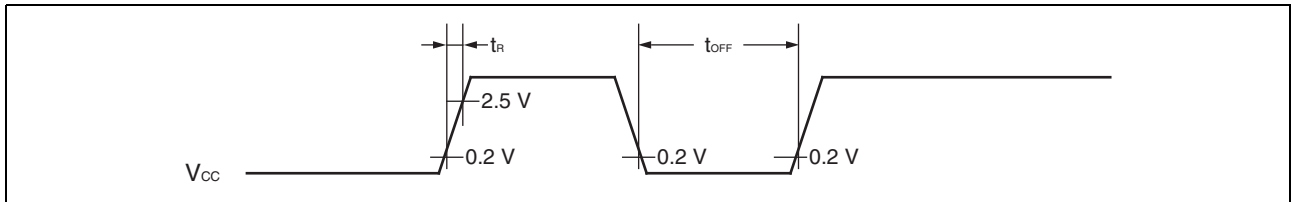

Note: A sudden change of power supply voltage may activate the power-on reset function. When changing the power supply voltage during the operation, set the slope of rising to a value below within 30 mV/ms as shown below.

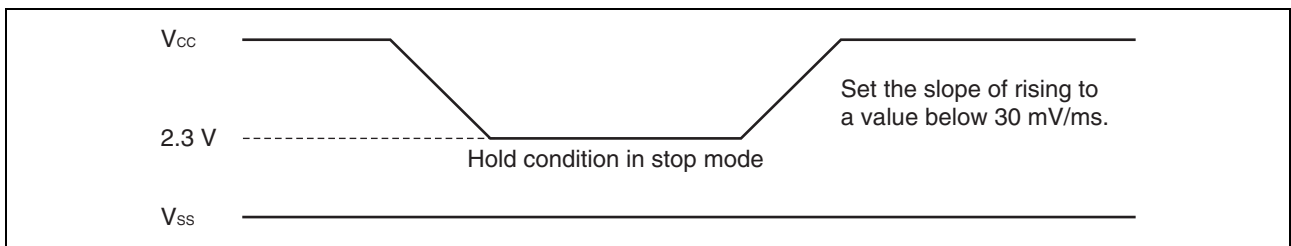

18.4.5 Peripheral Input Timing

($V_{CC} = 5.0\text{ V} \pm 10\%$, $V_{SS} = 0.0\text{ V}$, $T_A = -40^\circ\text{C}$ to $+85^\circ\text{C}$)

Parameter	Symbol	Pin name	Value		Unit
			Min	Max	
Peripheral input “H” pulse width	t_{LH}	INT00 to INT09, EC0, EC1, TI1, TRG1	$2 t_{MCLK}^*$	—	ns
Peripheral input “L” pulse width	t_{HL}	TRG1	$2 t_{MCLK}^*$	—	ns

*: See “Source Clock/Machine Clock” for t_{MCLK} .

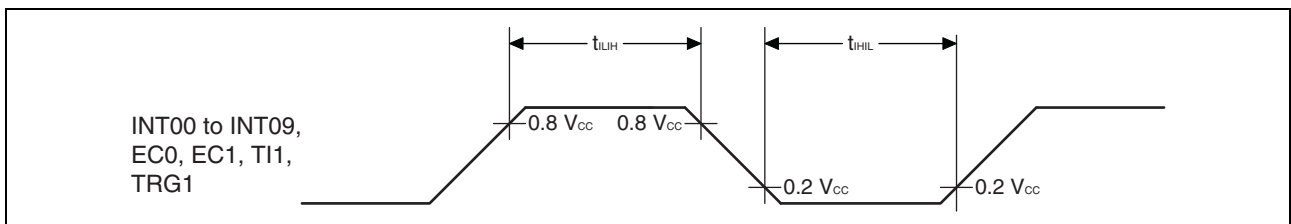

18.4.6 LIN-UART Timing

Sampling is executed at the rising edge of the sampling clock*¹, and serial clock delay is disabled*².
 (ESCR register : SCES bit = 0, ECCR register : SCDE bit = 0)

(V_{CC} = 5.0 V±10%, V_{SS} = 0.0 V, T_A = -40°C to +85°C)

Parameter	Symbol	Pin name	Condition	Value		Unit
				Min	Max	
Serial clock cycle time	t _{SCYC}	SCK	Internal clock operation output pin: C _L = 80 pF + 1 TTL	5 t _{MCLK} * ³	—	ns
SCK↓ → SOT delay time	t _{SLOVI}	SCK, SOT		-50	+50	ns
Valid SIN → SCK↑	t _{IVSHI}	SCK, SIN		t _{MCLK} * ³ + 80	—	ns
SCK↑ → valid SIN hold time	t _{SHIXI}	SCK, SIN		0	—	ns
Serial clock “L” pulse width	t _{SLSH}	SCK	External clock operation output pin: C _L = 80 pF + 1 TTL	3 t _{MCLK} * ³ - t _R	—	ns
Serial clock “H” pulse width	t _{SHSL}	SCK		t _{MCLK} * ³ + 10	—	ns
SCK↓ → SOT delay time	t _{SLOVE}	SCK, SOT		—	2 t _{MCLK} * ³ + 60	ns
Valid SIN → SCK↑	t _{IVSHE}	SCK, SIN		30	—	ns
SCK↑ → valid SIN hold time	t _{SHIXE}	SCK, SIN		t _{MCLK} * ³ + 30	—	ns
SCK falling time	t _F	SCK		—	10	ns
SCK rising time	t _R	SCK		—	10	ns

*1: There is a function used to choose whether the sampling of reception data is performed at a rising edge or a falling edge of the serial clock.

*2: The serial clock delay function is a function used to delay the output signal of the serial clock for half the clock.

*3: See “Source Clock/Machine Clock” for t_{MCLK}.

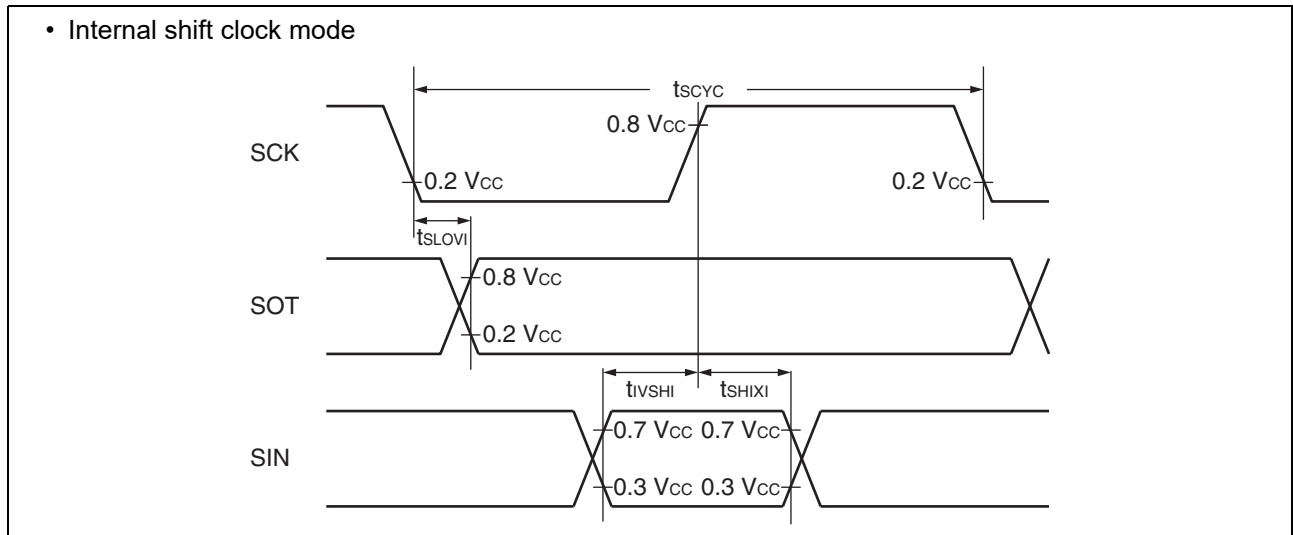

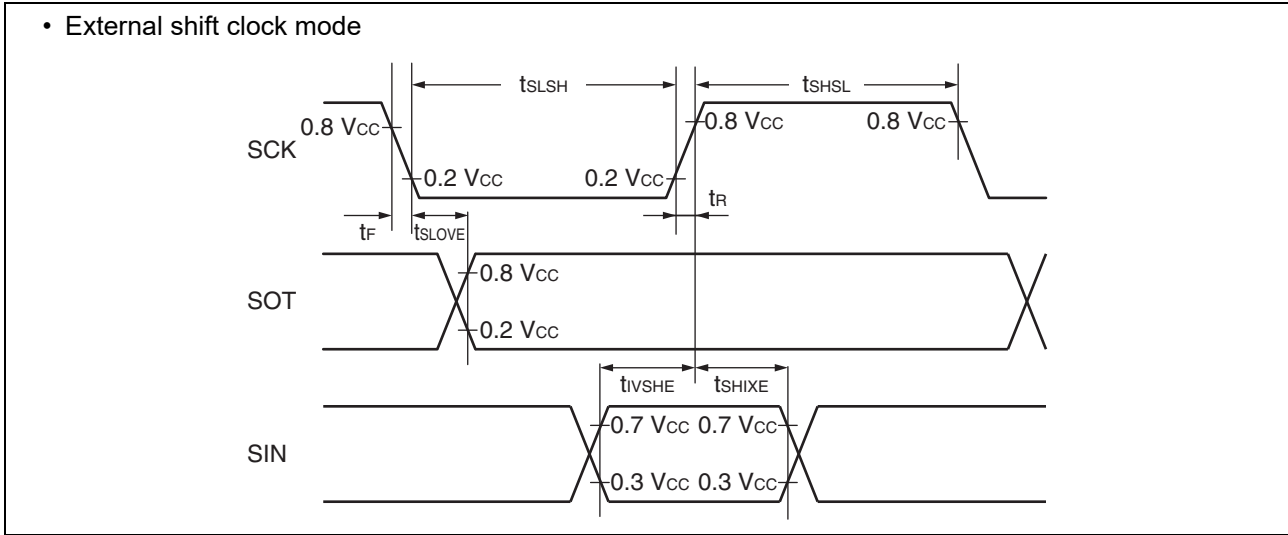

Sampling is executed at the falling edge of the sampling clock*1, and serial clock delay is disabled*2.
 (ESCR register : SCES bit = 1, ECCR register : SCDE bit = 0)

(V_{CC} = 5.0 V ± 10%, V_{SS} = 0.0 V, T_A = -40°C to +85°C)

Parameter	Symbol	Pin name	Condition	Value		Unit
				Min	Max	
Serial clock cycle time	t _{SCYC}	SCK	Internal clock operation output pin: C _L = 80 pF + 1 TTL	5 t _{MCLK} *3	—	ns
SCK↑ → SOT delay time	t _{SHOVI}	SCK, SOT		-50	+50	ns
Valid SIN → SCK↓	t _{IVSLI}	SCK, SIN		t _{MCLK} *3 + 80	—	ns
SCK↓ → valid SIN hold time	t _{SLIXI}	SCK, SIN		0	—	ns
Serial clock “H” pulse width	t _{SHSL}	SCK	External clock operation output pin: C _L = 80 pF + 1 TTL	3 t _{MCLK} *3 - t _R	—	ns
Serial clock “L” pulse width	t _{SLSH}	SCK		t _{MCLK} *3 + 10	—	ns
SCK↑ → SOT delay time	t _{SHOVE}	SCK, SOT		—	2 t _{MCLK} *3 + 60	ns
Valid SIN → SCK↓	t _{IVSLE}	SCK, SIN		30	—	ns
SCK↓ → valid SIN hold time	t _{SLIXE}	SCK, SIN		t _{MCLK} *3 + 30	—	ns
SCK falling time	t _F	SCK		—	10	ns
SCK rising time	t _R	SCK		—	10	ns

*1: There is a function used to choose whether the sampling of reception data is performed at a rising edge or a falling edge of the serial clock.

*2: The serial clock delay function is a function used to delay the output signal of the serial clock for half the clock.

*3: See “Source Clock/Machine Clock” for t_{MCLK}.

• Internal shift clock mode

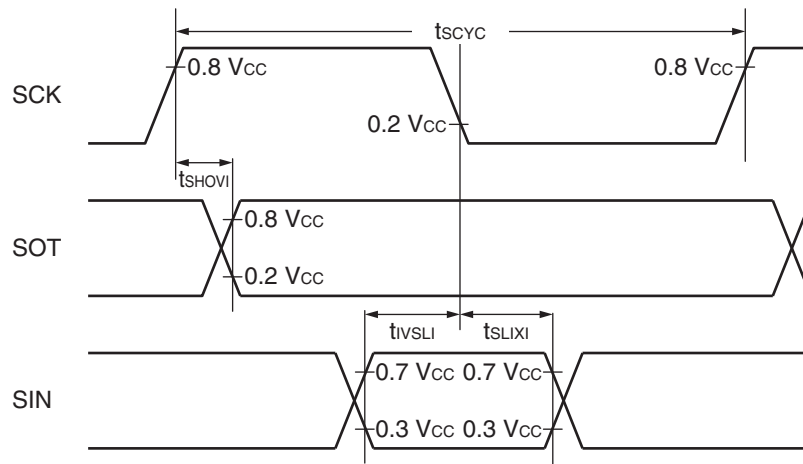

• External shift clock mode

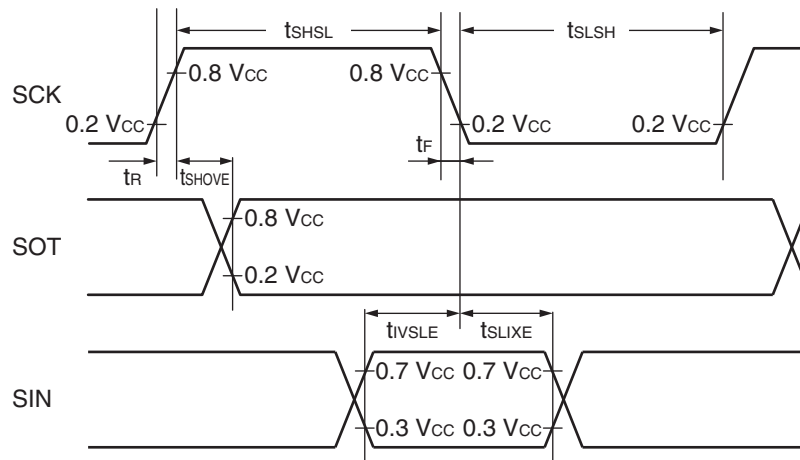

Sampling is executed at the rising edge of the sampling clock*¹, and serial clock delay is enabled*².
 (ESCR register : SCES bit = 0, ECCR register : SCDE bit = 1)

(V_{CC} = 5.0 V±10%, V_{SS} = 0.0 V, T_A = -40°C to +85°C)

Parameter	Symbol	Pin name	Condition	Value		Unit
				Min	Max	
Serial clock cycle time	t _{SCYC}	SCK	Internal clock operation output pin: C _L = 80 pF + 1 TTL	5 t _{MCLK} * ³	—	ns
SCK↑ → SOT delay time	t _{SHOVI}	SCK, SOT		-50	+50	ns
Valid SIN → SCK↓	t _{IVSLI}	SCK, SIN		t _{MCLK} * ³ + 80	—	ns
SCK↓ → valid SIN hold time	t _{SLIXI}	SCK, SIN		0	—	ns
SOT → SCK↓ delay time	t _{SOVLI}	SCK, SOT		3t _{MCLK} * ³ - 70	—	ns

*1: There is a function used to choose whether the sampling of reception data is performed at a rising edge or a falling edge of the serial clock.

*2: The serial clock delay function is a function used to delay the output signal of the serial clock for half the clock.

*3: See “Source Clock/Machine Clock” for t_{MCLK}.

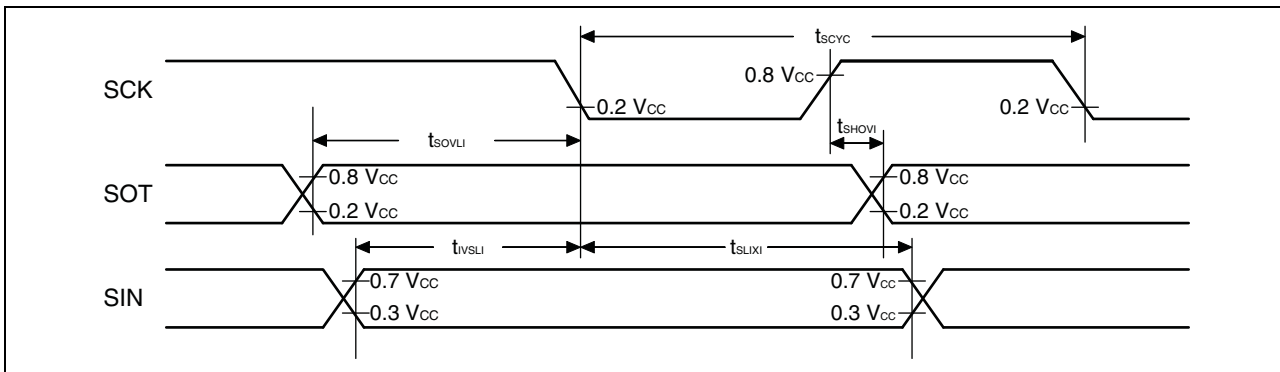

Sampling is executed at the falling edge of the sampling clock*¹, and serial clock delay is enabled*².

(ESCR register : SCES bit = 1, ECCR register : SCDE bit = 1)

(V_{CC} = 5.0 V±10%, V_{SS} = 0.0 V, T_A = -40°C to +85°C)

Parameter	Symbol	Pin name	Condition	Value		Unit
				Min	Max	
Serial clock cycle time	t _{SCYC}	SCK	Internal clock operation output pin: C _L = 80 pF + 1 TTL	5 t _{MCLK} * ³	—	ns
SCK↓ → SOT delay time	t _{SLOVI}	SCK, SOT		-50	+50	ns
Valid SIN → SCK↑	t _{IVSHI}	SCK, SIN		t _{MCLK} * ³ + 80	—	ns
SCK↑ → valid SIN hold time	t _{SHIXI}	SCK, SIN		0	—	ns
SOT → SCK↑ delay time	t _{SOVHI}	SCK, SOT		3t _{MCLK} * ³ - 70	—	ns

*1: There is a function used to choose whether the sampling of reception data is performed at a rising edge or a falling edge of the serial clock.

*2: The serial clock delay function is a function used to delay the output signal of the serial clock for half the clock.

*3: See “Source Clock/Machine Clock” for t_{MCLK}.

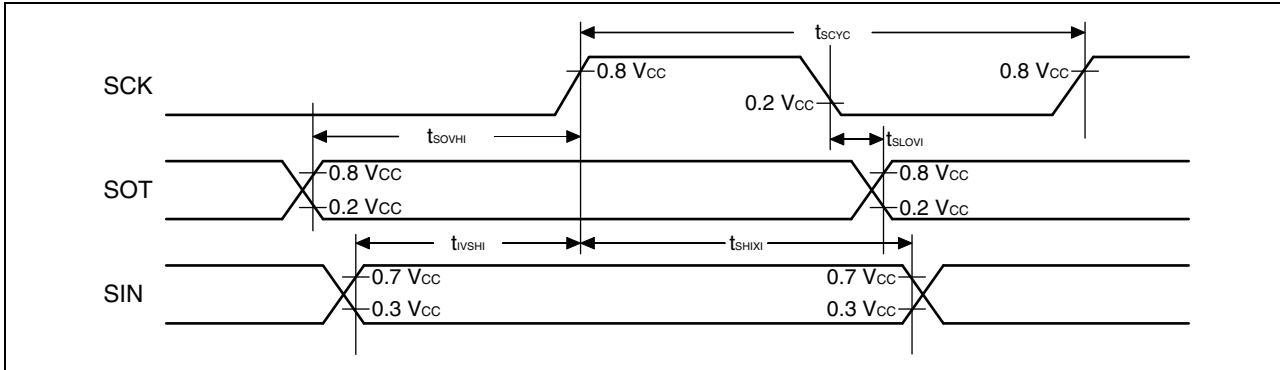

18.4.7 Low-voltage Detection

(V_{SS} = 0.0 V, T_A = -40°C to +85°C)

Parameter	Symbol	Value			Unit	Remarks
		Min	Typ	Max		
Release voltage*	V _{DL+}	2.52	2.7	2.88	V	At power supply rise
		2.61	2.8	2.99		
		2.89	3.1	3.31		
		3.08	3.3	3.52		
Detection voltage*	V _{DL-}	2.43	2.6	2.77	V	At power supply fall
		2.52	2.7	2.88		
		2.80	3	3.20		
		2.99	3.2	3.41		
Hysteresis width	V _{HYS}	—	—	100	mV	
Power supply start voltage	V _{off}	—	—	2.3	V	
Power supply end voltage	V _{on}	4.9	—	—	V	
Power supply voltage change time (at power supply rise)	t _r	650	—	—	μs	Slope of power supply that the reset release signal generates within the rating (V _{DL+})
Power supply voltage change time (at power supply fall)	t _r	650	—	—	μs	Slope of power supply that the reset detection signal generates within the rating (V _{DL-})
Reset release delay time	t _{d1}	—	—	30	μs	
Reset detection delay time	t _{d2}	—	—	30	μs	
LVD reset threshold voltage transition stabilization time	t _{stb}	10	—	—	μs	

*: The release voltage and the detection voltage can be selected by using the LVD reset voltage selection ID register (LVDR) in the low-voltage detection reset circuit. For details of the LVDR register, refer to “CHAPTER 16 LOW-VOLTAGE DETECTION RESET CIRCUIT” in “New 8FX CY95630H Series Hardware Manual”.

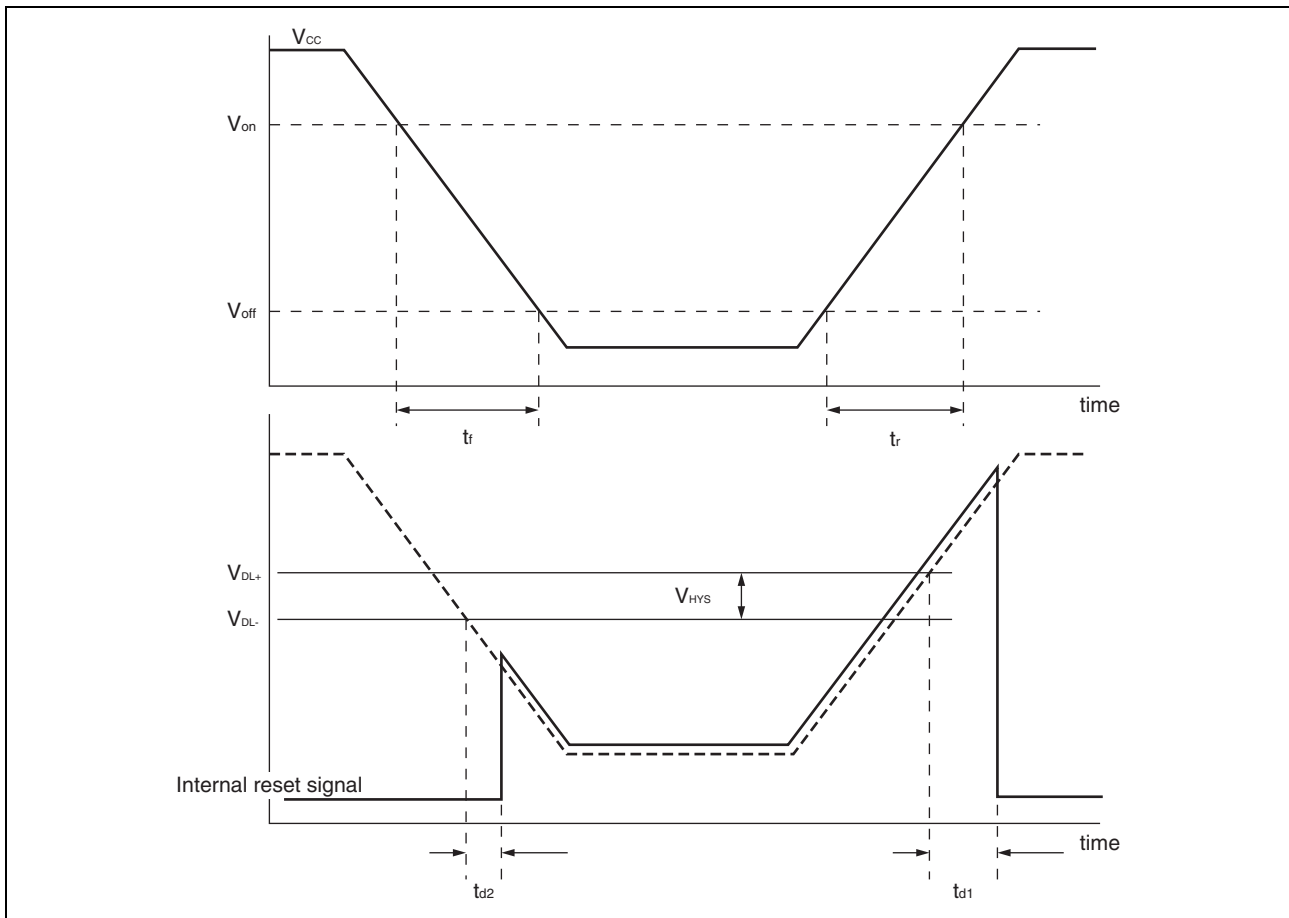

18.4.8 I²C Bus Interface Timing

(V_{CC} = 5.0 V ± 10%, V_{SS} = 0.0 V, T_A = -40°C to +85°C)

Parameter	Symbol	Pin name	Condition	Value				Unit
				Standard-mode		Fast-mode		
				Min	Max	Min	Max	
SCL clock frequency	f _{SCL}	SCL	R = 1.7 kΩ, C = 50 pF*1	0	100	0	400	kHz
(Repeated) START condition hold time SDA ↓ → SCL ↓	t _{HD;STA}	SCL, SDA		4.0	—	0.6	—	μs
SCL clock "L" width	t _{LOW}	SCL		4.7	—	1.3	—	μs
SCL clock "H" width	t _{HIGH}	SCL		4.0	—	0.6	—	μs
(Repeated) START condition setup time SCL ↑ → SDA ↓	t _{SU;STA}	SCL, SDA		4.7	—	0.6	—	μs
Data hold time SCL ↓ → SDA ↓↑	t _{HD;DAT}	SCL, SDA		0	3.45*2	0	0.9*3	μs
Data setup time SDA ↓↑ → SCL ↑	t _{SU;DAT}	SCL, SDA		0.25	—	0.1	—	μs
STOP condition setup time SCL ↑ → SDA ↑	t _{SU;STO}	SCL, SDA		4	—	0.6	—	μs
Bus free time between STOP condition and START condition	t _{BUF}	SCL, SDA		4.7	—	1.3	—	μs

- *1: R represents the pull-up resistor of the SCL and SDA lines, and C the load capacitor of the SCL and SDA lines.
- *2: The maximum t_{HD;DAT} in the Standard-mode is applicable only when the time during which the device is holding the SCL signal at "L" (t_{LOW}) does not extend.
- *3: A Fast-mode I²C-bus device can be used in a Standard-mode I²C-bus system, provided that the condition of t_{SU;DAT} ≥ 250 ns is fulfilled.

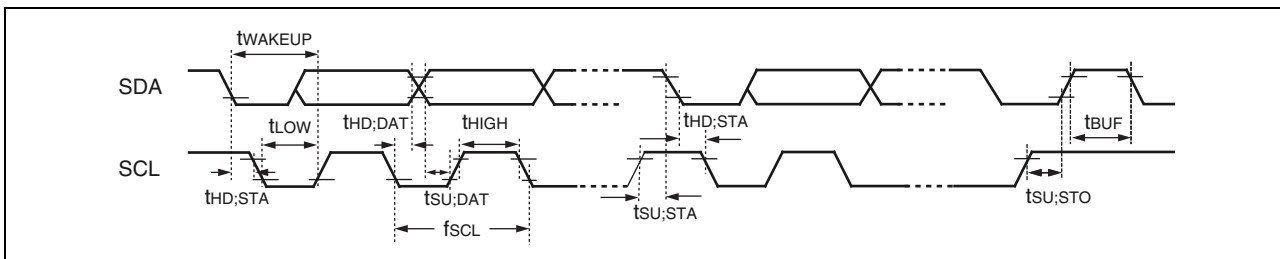

(V_{CC} = 5.0 V ± 10%, V_{SS} = 0.0 V, T_A = -40°C to +85°C)

Parameter	Symbol	Pin name	Condition	Value*2		Unit	Remarks
				Min	Max		
SCL clock "L" width	t _{LOW}	SCL	R = 1.7 kΩ, C = 50 pF*1	$(2 + nm/2)t_{MCLK} - 20$	—	ns	Master mode
SCL clock "H" width	t _{HIGH}	SCL		$(nm/2)t_{MCLK} - 20$	$(nm/2)t_{MCLK} + 20$	ns	Master mode
START condition hold time	t _{HD;STA}	SCL, SDA		$(-1 + nm/2)t_{MCLK} - 20$	$(-1 + nm)t_{MCLK} + 20$	ns	Master mode Maximum value is applied when m, n = 1, 8. Otherwise, the minimum value is applied.
STOP condition setup time	t _{SU;STO}	SCL, SDA		$(1 + nm/2)t_{MCLK} - 20$	$(1 + nm/2)t_{MCLK} + 20$	ns	Master mode
START condition setup time	t _{SU;STA}	SCL, SDA		$(1 + nm/2)t_{MCLK} - 20$	$(1 + nm/2)t_{MCLK} + 20$	ns	Master mode
Bus free time between STOP condition and START condition	t _{BUF}	SCL, SDA		$(2nm + 4)t_{MCLK} - 20$	—	ns	
Data hold time	t _{HD;DAT}	SCL, SDA		$3t_{MCLK} - 20$	—	ns	Master mode
Data setup time	t _{SU;DAT}	SCL, SDA		$(-2 + nm/2)t_{MCLK} - 20$	$(-1 + nm/2)t_{MCLK} + 20$	ns	Master mode It is assumed that "L" of SCL is not extended. The minimum value is applied to the first bit of continuous data. Otherwise, the maximum value is applied.
Setup time between clearing interrupt and SCL rising	t _{SU;INT}	SCL		$(nm/2)t_{MCLK} - 20$	$(1 + nm/2)t_{MCLK} + 20$	ns	The minimum value is applied to the interrupt at the ninth SCL↓. The maximum value is applied to the interrupt at the eighth SCL↓.
SCL clock "L" width	t _{LOW}	SCL		$4t_{MCLK} - 20$	—	ns	At reception
SCL clock "H" width	t _{HIGH}	SCL	$4t_{MCLK} - 20$	—	ns	At reception	

(Continued)

 ($V_{CC} = 5.0 V \pm 10\%$, $V_{SS} = 0.0 V$, $T_A = -40^\circ C$ to $+85^\circ C$)

Parameter	Symbol	Pin name	Condition	Value*2		Unit	Remarks
				Min	Max		
START condition detection	$t_{HD;STA}$	SCL, SDA	R = 1.7 k Ω , C = 50 pF*1	$2 t_{MCLK} - 20$	—	ns	No START condition is detected when 1 t_{MCLK} is used at reception.
STOP condition detection	$t_{SU;STO}$	SCL, SDA		$2 t_{MCLK} - 20$	—	ns	No STOP condition is detected when 1 t_{MCLK} is used at reception.
RESTART condition detection condition	$t_{SU;STA}$	SCL, SDA		$2 t_{MCLK} - 20$	—	ns	No RESTART condition is detected when 1 t_{MCLK} is used at reception.
Bus free time	t_{BUF}	SCL, SDA		$2 t_{MCLK} - 20$	—	ns	At reception
Data hold time	$t_{HD;DAT}$	SCL, SDA		$2 t_{MCLK} - 20$	—	ns	At slave transmission mode
Data setup time	$t_{SU;DAT}$	SCL, SDA		$t_{LOW} - 3 t_{MCLK} - 20$	—	ns	At slave transmission mode
Data hold time	$t_{HD;DAT}$	SCL, SDA		0	—	ns	At reception
Data setup time	$t_{SU;DAT}$	SCL, SDA		$t_{MCLK} - 20$	—	ns	At reception
SDA \downarrow \rightarrow SCL \uparrow (with wakeup function in use)	t_{WAKEUP}	SCL, SDA		Oscillation stabilization wait time $+2 t_{MCLK} - 20$	—	ns	

*1: R represents the pull-up resistor of the SCL and SDA lines, and C the load capacitor of the SCL and SDA lines.

*2: • See “Source Clock/Machine Clock” for t_{MCLK} .

- m represents the CS[4:3] bits in the I²C clock control register ch. 0 (ICCR0).
- n represents the CS[2:0] bits in the I²C clock control register ch. 0 (ICCR0).
- The actual timing of the I²C bus interface is determined by the values of m and n set by the machine clock (t_{MCLK}) and the CS[4:0] bits in the ICCR0 register.
- Standard-mode:
 - m and n can be set to values in the following range: $0.9 \text{ MHz} < t_{MCLK} \text{ (machine clock)} < 16.25 \text{ MHz}$.
 - The usable frequencies of the machine clock are determined by the settings of m and n as shown below.
 - (m, n) = (1, 8) : $0.9 \text{ MHz} < t_{MCLK} \leq 1 \text{ MHz}$
 - (m, n) = (1, 22), (5, 4), (6, 4), (7, 4), (8, 4) : $0.9 \text{ MHz} < t_{MCLK} \leq 2 \text{ MHz}$
 - (m, n) = (1, 38), (5, 8), (6, 8), (7, 8), (8, 8) : $0.9 \text{ MHz} < t_{MCLK} \leq 4 \text{ MHz}$
 - (m, n) = (1, 98), (5, 22), (6, 22), (7, 22) : $0.9 \text{ MHz} < t_{MCLK} \leq 10 \text{ MHz}$
 - (m, n) = (8, 22) : $0.9 \text{ MHz} < t_{MCLK} \leq 16.25 \text{ MHz}$
- Fast-mode:
 - m and n can be set to values in the following range: $3.3 \text{ MHz} < t_{MCLK} \text{ (machine clock)} < 16.25 \text{ MHz}$.
 - The usable frequencies of the machine clock are determined by the settings of m and n as shown below.
 - (m, n) = (1, 8) : $3.3 \text{ MHz} < t_{MCLK} \leq 4 \text{ MHz}$
 - (m, n) = (1, 22), (5, 4) : $3.3 \text{ MHz} < t_{MCLK} \leq 8 \text{ MHz}$
 - (m, n) = (1, 38), (6, 4), (7, 4), (8, 4) : $3.3 \text{ MHz} < t_{MCLK} \leq 10 \text{ MHz}$
 - (m, n) = (5, 8) : $3.3 \text{ MHz} < t_{MCLK} \leq 16.25 \text{ MHz}$

18.4.9 UART/SIO, Serial I/O Timing

($V_{CC} = 5.0 V \pm 10\%$, $V_{SS} = 0.0 V$, $T_A = -40^\circ C$ to $+85^\circ C$)

Parameter	Symbol	Pin name	Condition	Value		Unit
				Min	Max	
Serial clock cycle time	t_{SCYC}	UCK0	Internal clock operation	$4 t_{MCLK}^*$	—	ns
UCK ↓ → UO time	t_{SLOV}	UCK0, UO0		-190	+190	ns
Valid UI → UCK ↑	t_{VSH}	UCK0, UI0		$2 t_{MCLK}^*$	—	ns
UCK ↑ → valid UI hold time	t_{SHIX}	UCK0, UI0		$2 t_{MCLK}^*$	—	ns
Serial clock "H" pulse width	t_{SHSL}	UCK0	External clock operation	$4 t_{MCLK}^*$	—	ns
Serial clock "L" pulse width	t_{SLSH}	UCK0		$4 t_{MCLK}^*$	—	ns
UCK ↓ → UO time	t_{SLOV}	UCK0, UO0		—	190	ns
Valid UI → UCK ↑	t_{VSH}	UCK0, UI0		$2 t_{MCLK}^*$	—	ns
UCK ↑ → valid UI hold time	t_{SHIX}	UCK0, UI0	$2 t_{MCLK}^*$	—	ns	

*: See "Source Clock/Machine Clock" for t_{MCLK} .

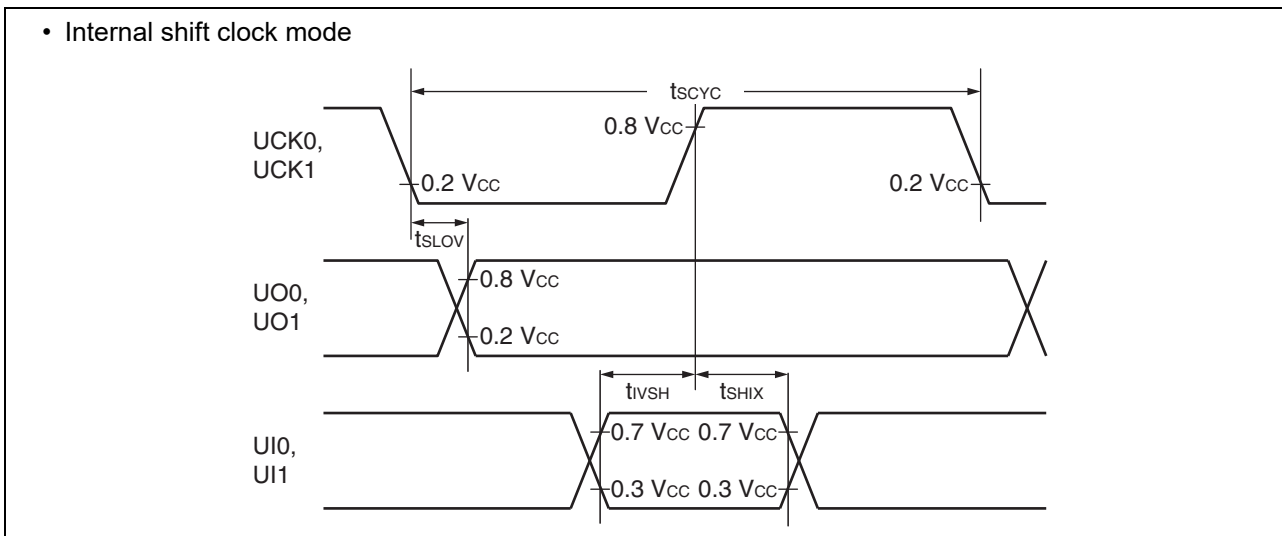

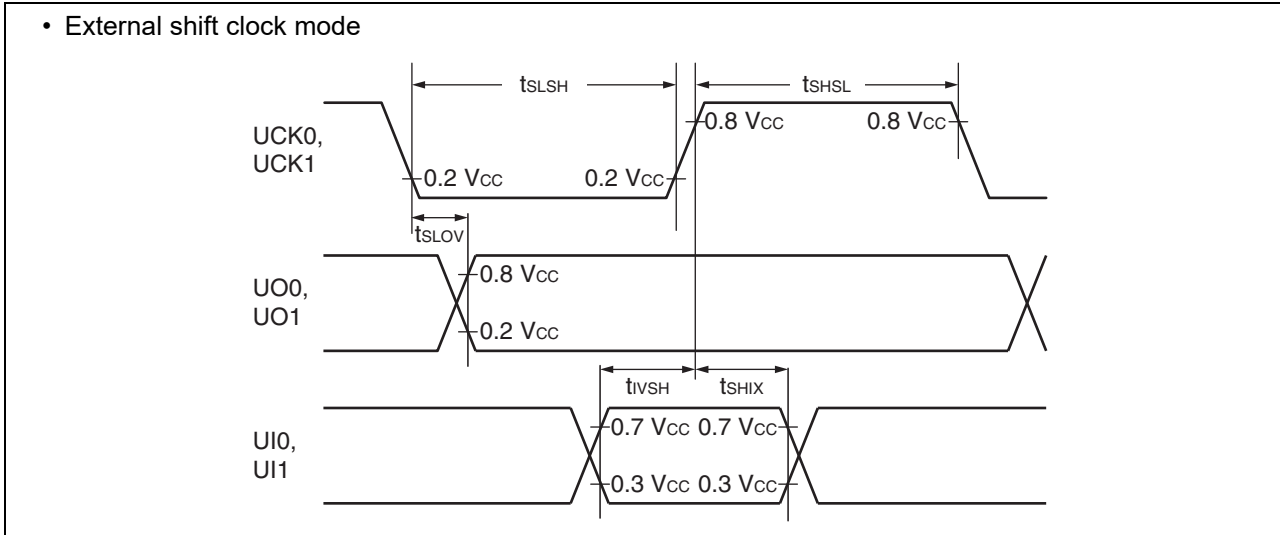

18.4.10 MPG Input Timing

(V_{CC} = 5.0 V ± 10%, V_{SS} = 0.0 V, T_A = -40°C to +85°C)

Parameter	Symbol	Pin name	Condition	Value		Unit	Remarks
				Min	Max		
Input pulse width	t _{TIWH} , t _{TIWL}	SNI0 to SNI2, DTTI	—	4 t _{MCLK}	—	ns	

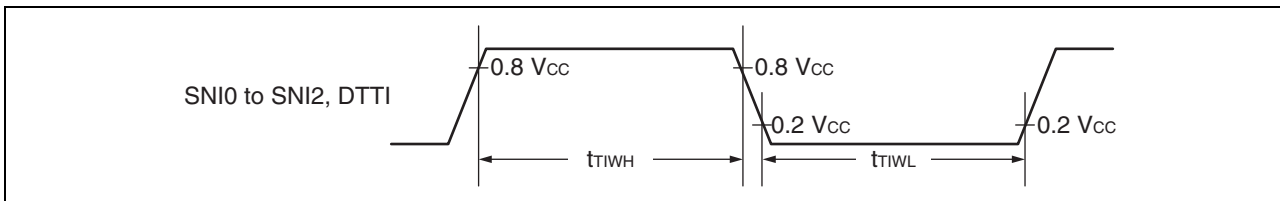

18.4.11 Comparator Timing

(V_{CC} = 2.4 V to 5.5 V, V_{SS} = 0.0 V, T_A = -40°C to +85°C)

Parameter	Pin name	Value			Unit	Remarks
		Min	Typ	Max		
Voltage range	CMP0_P, CMP0_N	0	—	V _{CC} - 1.3	V	
Offset voltage	CMP0_P, CMP0_N	-15	—	+15	mV	
Delay time	CMP0_O	—	650	1200	ns	Overdrive 5 mV
		—	140	420	ns	Overdrive 50 mV
Power down delay	CMP0_O	—	—	1200	ns	Power down recovery PD: 1 → 0
Power up stabilization time	CMP0_O	—	—	1200	ns	Output stabilization time at power up

18.5 A/D Converter

18.5.1 A/D Converter Electrical Characteristics

($V_{CC} = 2.7\text{ V to }5.5\text{ V}$, $V_{SS} = 0.0\text{ V}$, $T_A = -40^\circ\text{C to }+85^\circ\text{C}$)

Parameter	Symbol	Value			Unit	Remarks
		Min	Typ	Max		
Resolution	—	—	—	10	bit	
Total error		-3	—	+3	LSB	
Linearity error		-2.5	—	+2.5	LSB	
Differential linearity error		-1.9	—	+1.9	LSB	
Zero transition voltage	V_{0T}	$V_{SS} - 1.5\text{ LSB}$	$V_{SS} + 0.5\text{ LSB}$	$V_{SS} + 2.5\text{ LSB}$	V	
Full-scale transition voltage	V_{FST}	$V_{CC} - 4.5\text{ LSB}$	$V_{CC} - 2\text{ LSB}$	$V_{CC} + 0.5\text{ LSB}$	V	
Compare time	—	3	—	10	μs	$2.7\text{ V} \leq V_{CC} \leq 5.5\text{ V}$
Sampling time	—	0.941	—	∞	μs	$2.7\text{ V} \leq V_{CC} \leq 5.5\text{ V}$, with external impedance < 3.3 k Ω and external capacitance = 10 pF
Analog input current	I_{AIN}	-0.3	—	+0.3	μA	
Analog input voltage	V_{AIN}	V_{SS}	—	V_{CC}	V	

18.5.2 Notes on Using A/D Converter

- External impedance of analog input and its sampling time

The A/D converter of the CY95630H Series has a sample and hold circuit. If the external impedance is too high to keep sufficient sampling time, the analog voltage charged to the capacitor of the internal sample and hold circuit is insufficient, adversely affecting A/D conversion precision. Therefore, to satisfy the A/D conversion precision standard, considering the relationship between the external impedance and minimum sampling time, either adjust the register value and operating frequency or decrease the external impedance so that the sampling time is longer than the minimum value. In addition, if sufficient sampling time cannot be secured, connect a capacitor of about 0.1 μF to the analog input pin.

- Analog input equivalent circuit

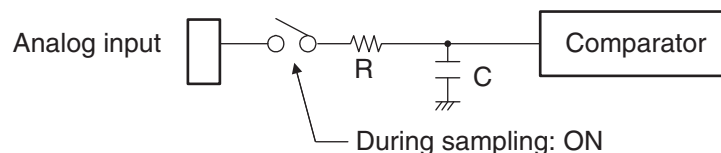

V_{CC}	R	C
$4.5\text{ V} \leq V_{CC} \leq 5.5\text{ V}$	1.45 k Ω (Max)	14.89 pF (Max)
$2.7\text{ V} \leq V_{CC} < 4.5\text{ V}$	2.7 k Ω (Max)	14.89 pF (Max)

Note: The values are reference values.

- Relationship between external impedance and minimum sampling time

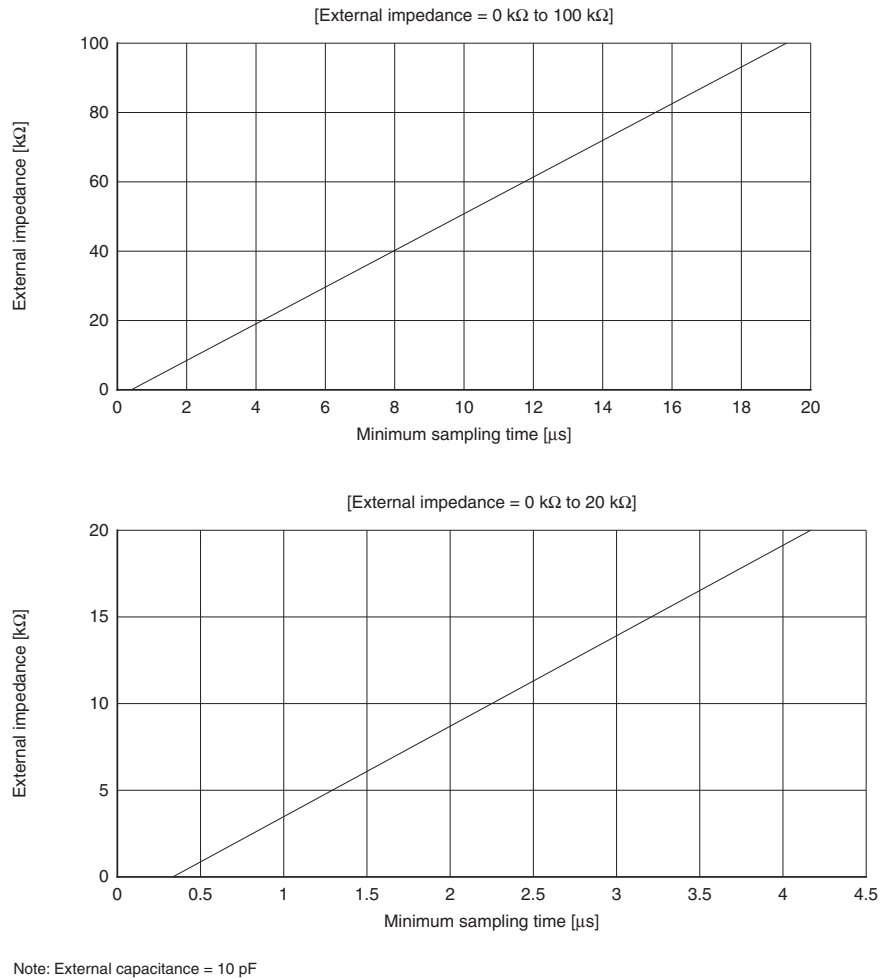

- A/D conversion error
As $|V_{CC} - V_{SS}|$ decreases, the A/D conversion error increases proportionately.

18.5.3 Definitions of A/D Converter Terms

- Resolution

It indicates the level of analog variation that can be distinguished by the A/D converter.
 When the number of bits is 10, analog voltage can be divided into $2^{10} = 1024$.

- Linearity error (unit: LSB)

It indicates how much an actual conversion value deviates from the straight line connecting the zero transition point (“0000000000” ← → “0000000001”) of a device to the full-scale transition point (“1111111111” ← → “1111111110”) of the same device.

- Differential linear error (unit: LSB)

It indicates how much the input voltage required to change the output code by 1 LSB deviates from an ideal value.

- Total error (unit: LSB)

It indicates the difference between an actual value and a theoretical value. The error can be caused by a zero transition error, a full-scale transition errors, a linearity error, a quantum error, or noise.

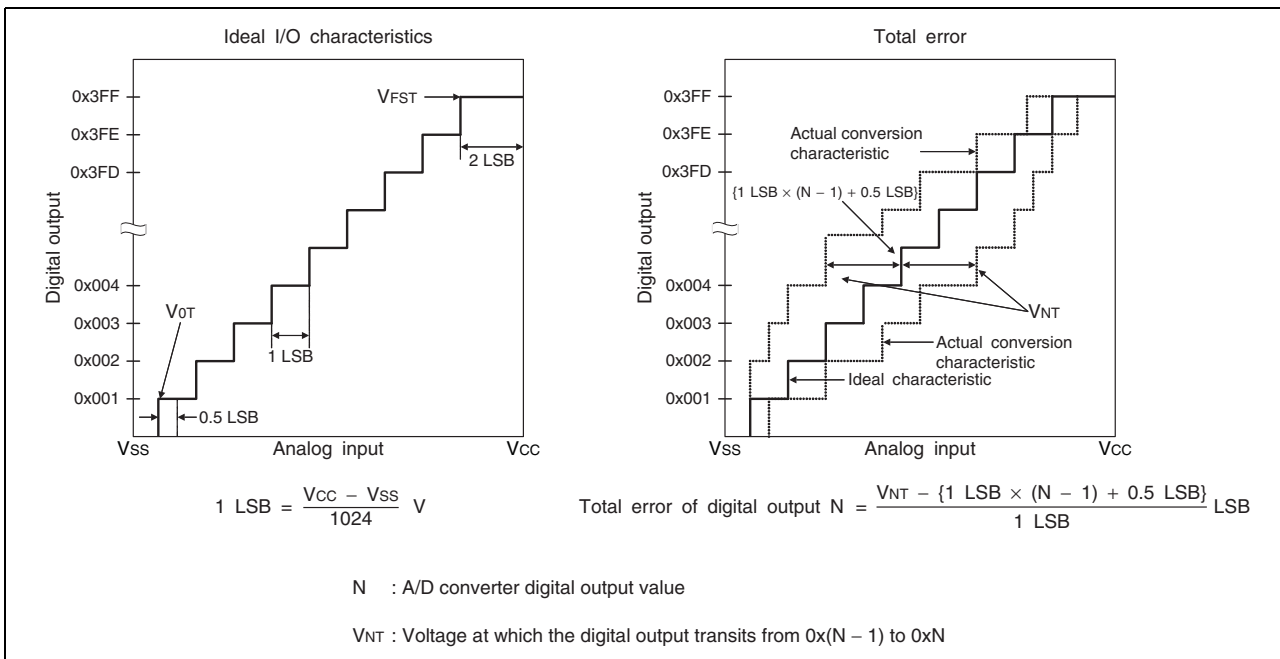

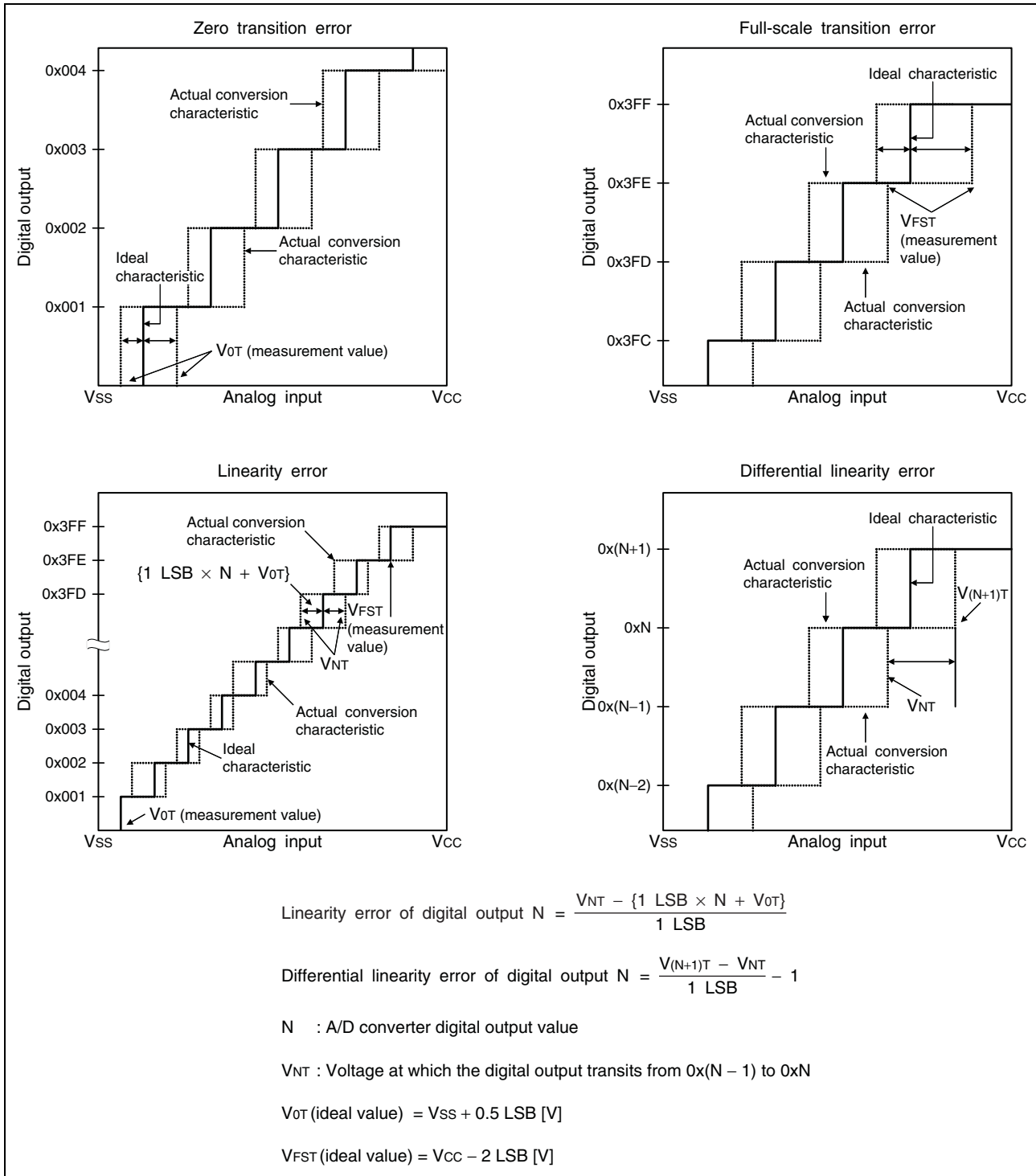

18.6 Flash Memory Program/Erase Characteristics

Parameter	Value			Unit	Remarks
	Min	Typ	Max		
Sector erase time (2 Kbyte sector)	—	0.3* ¹	1.6* ²	s	The time of writing "0x00" prior to erasure is excluded.
Sector erase time (32 Kbyte sector)	—	0.6* ¹	3.1* ²	s	The time of writing "0x00" prior to erasure is excluded.
Byte writing time	—	17	272	μs	System-level overhead is excluded.
Program/erase cycle	100000	—	—	cycle	
Power supply voltage at program/erase	2.4	—	5.5	V	
Flash memory data retention time	20* ³	—	—	year	Average T _A = +85°C Number of program/erase cycles: 1000 or below
	10* ³	—	—		Average T _A = +85°C Number of program/erase cycles: 1001 to 10000 inclusive
	5* ³	—	—		Average T _A = +85°C Number of program/erase cycles: 10001 or above

*1: V_{CC} = 5.5 V, T_A = +25°C, 0 cycle

*2: V_{CC} = 2.4 V, T_A = +85°C, 100000 cycles

*3: These values were converted from the result of a technology reliability assessment. (These values were converted from the result of a high temperature accelerated test using the Arrhenius equation with the average temperature being +85°C.)

19. Sample Characteristics

- Power supply current temperature characteristics

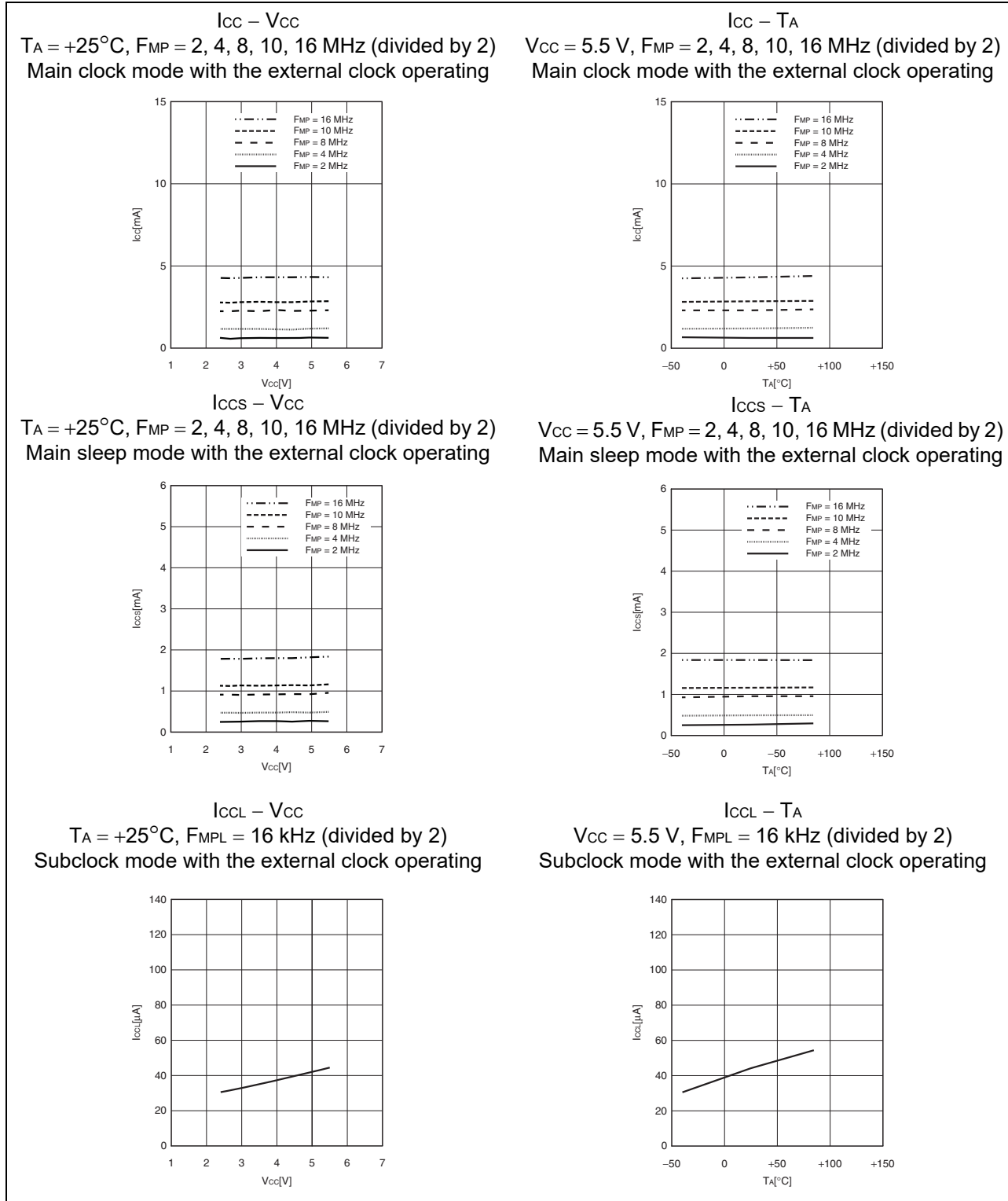

ICCLS – VCC

$T_A = +25^\circ\text{C}$, $F_{MPL} = 16\text{ kHz}$ (divided by 2)
Subsleep mode with the external clock operating

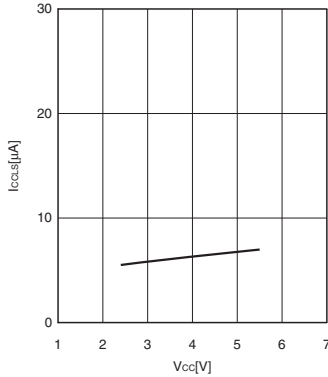

ICCLS – TA

$V_{CC} = 5.5\text{ V}$, $F_{MPL} = 16\text{ kHz}$ (divided by 2)
Subsleep mode with the external clock operating

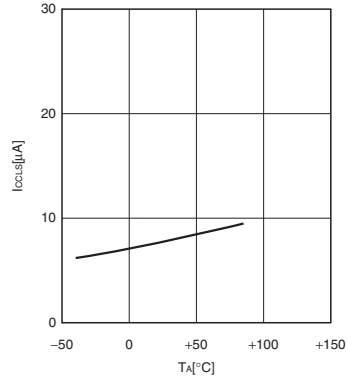

ICCT – VCC

$T_A = +25^\circ\text{C}$, $F_{MPL} = 16\text{ kHz}$ (divided by 2)
Watch mode with the external clock operating

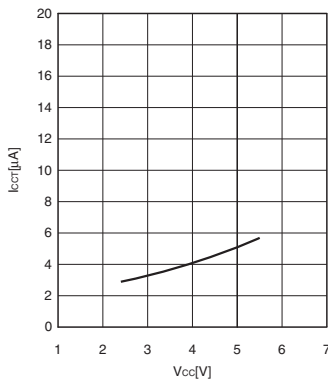

ICCT – TA

$V_{CC} = 5.5\text{ V}$, $F_{MPL} = 16\text{ kHz}$ (divided by 2)
Watch mode with the external clock operating

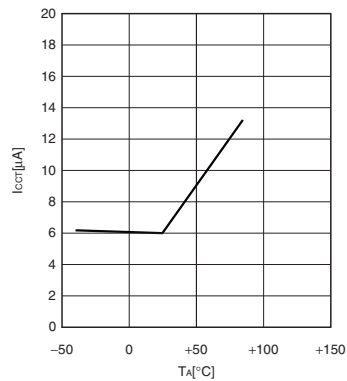

ICCTS – VCC

$T_A = +25^\circ\text{C}$, $F_{MP} = 2, 4, 8, 10, 16\text{ MHz}$ (divided by 2)
Time-base timer mode with the external clock operating

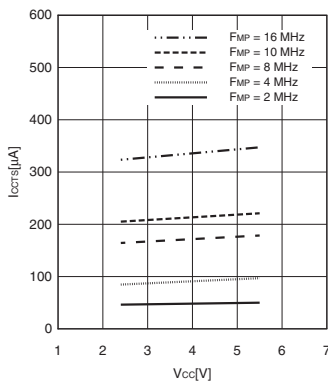

ICCTS – TA

$V_{CC} = 5.5\text{ V}$, $F_{MP} = 2, 4, 8, 10, 16\text{ MHz}$ (divided by 2)
Time-base timer mode with the external clock operating

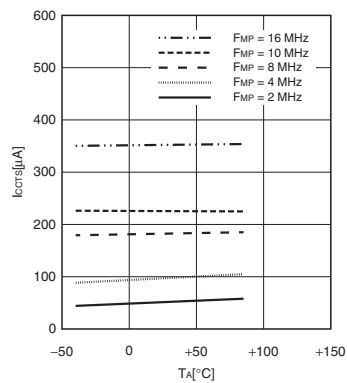

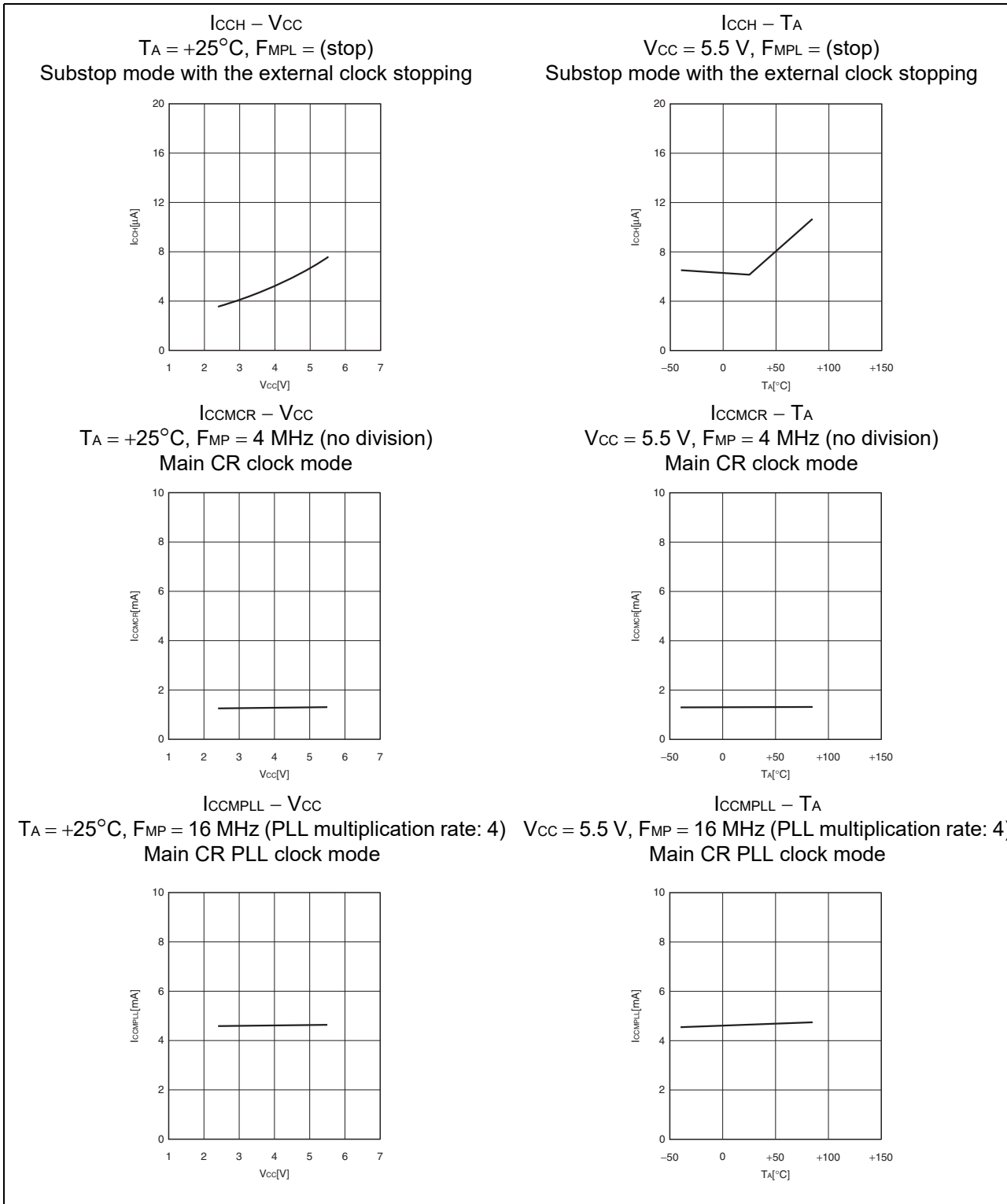

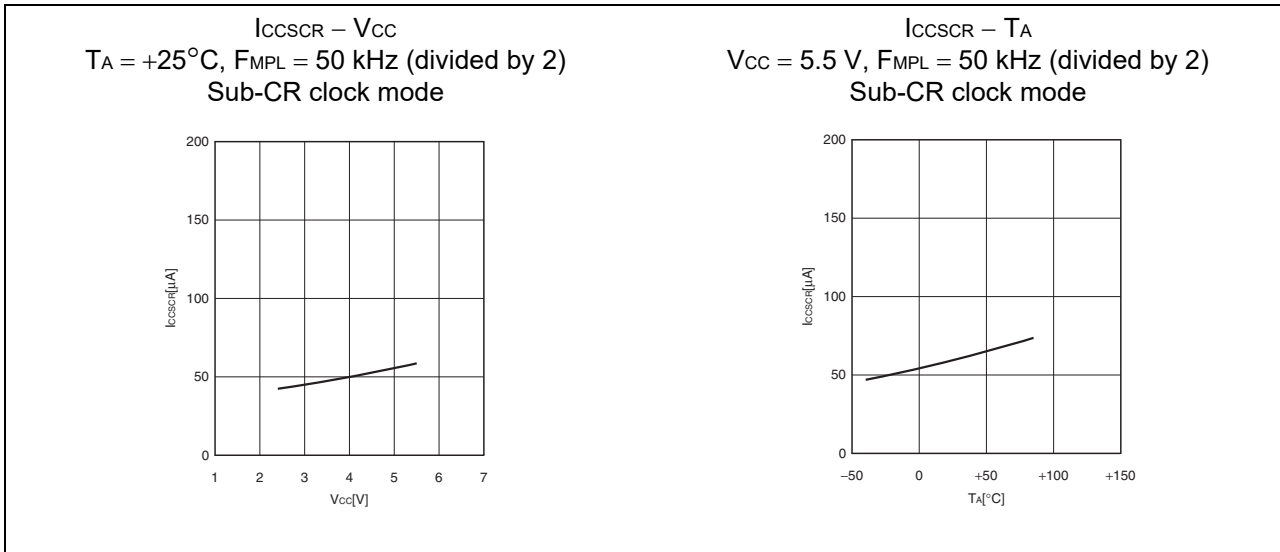

• Input voltage characteristics

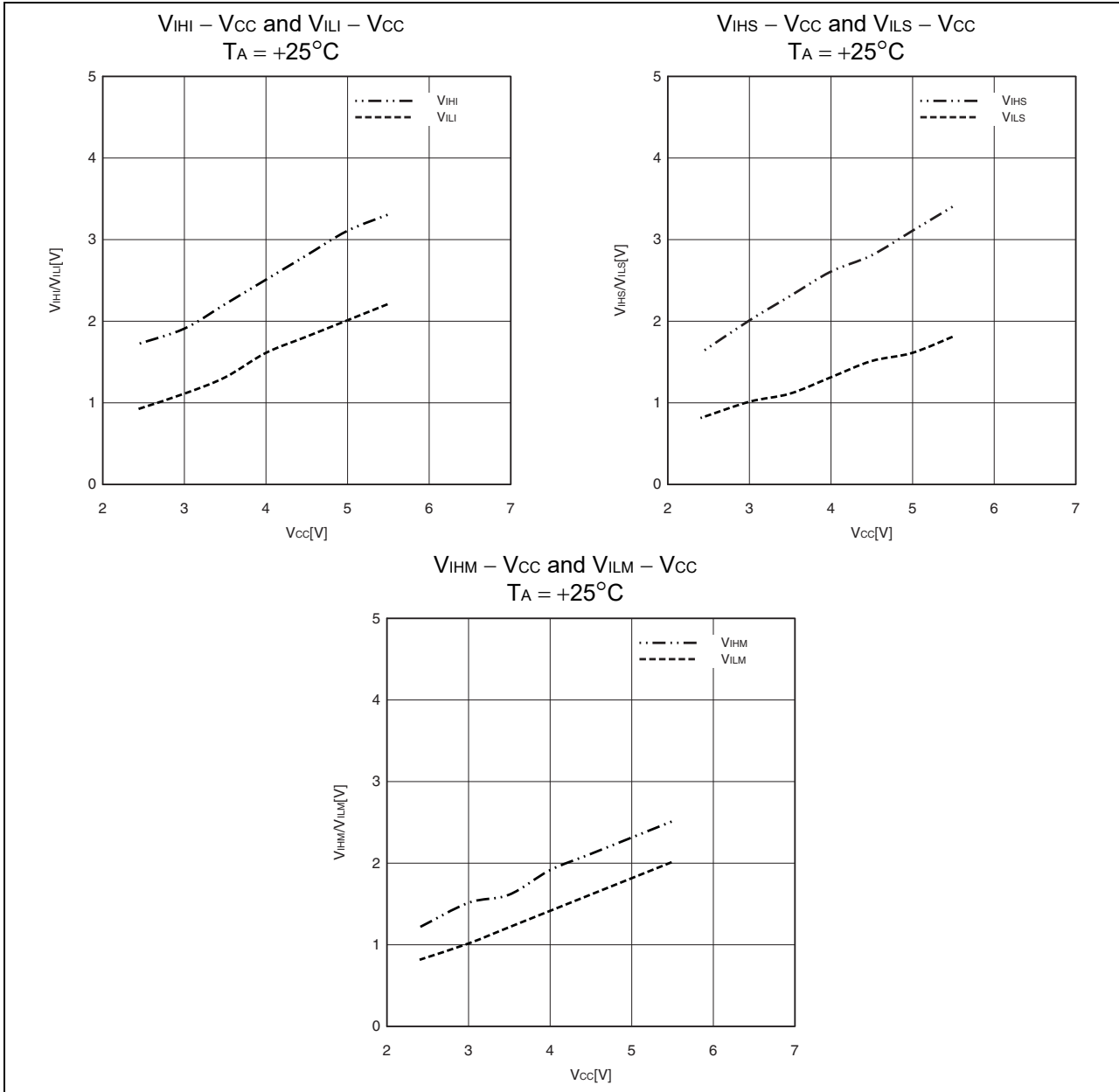

• Output voltage characteristics

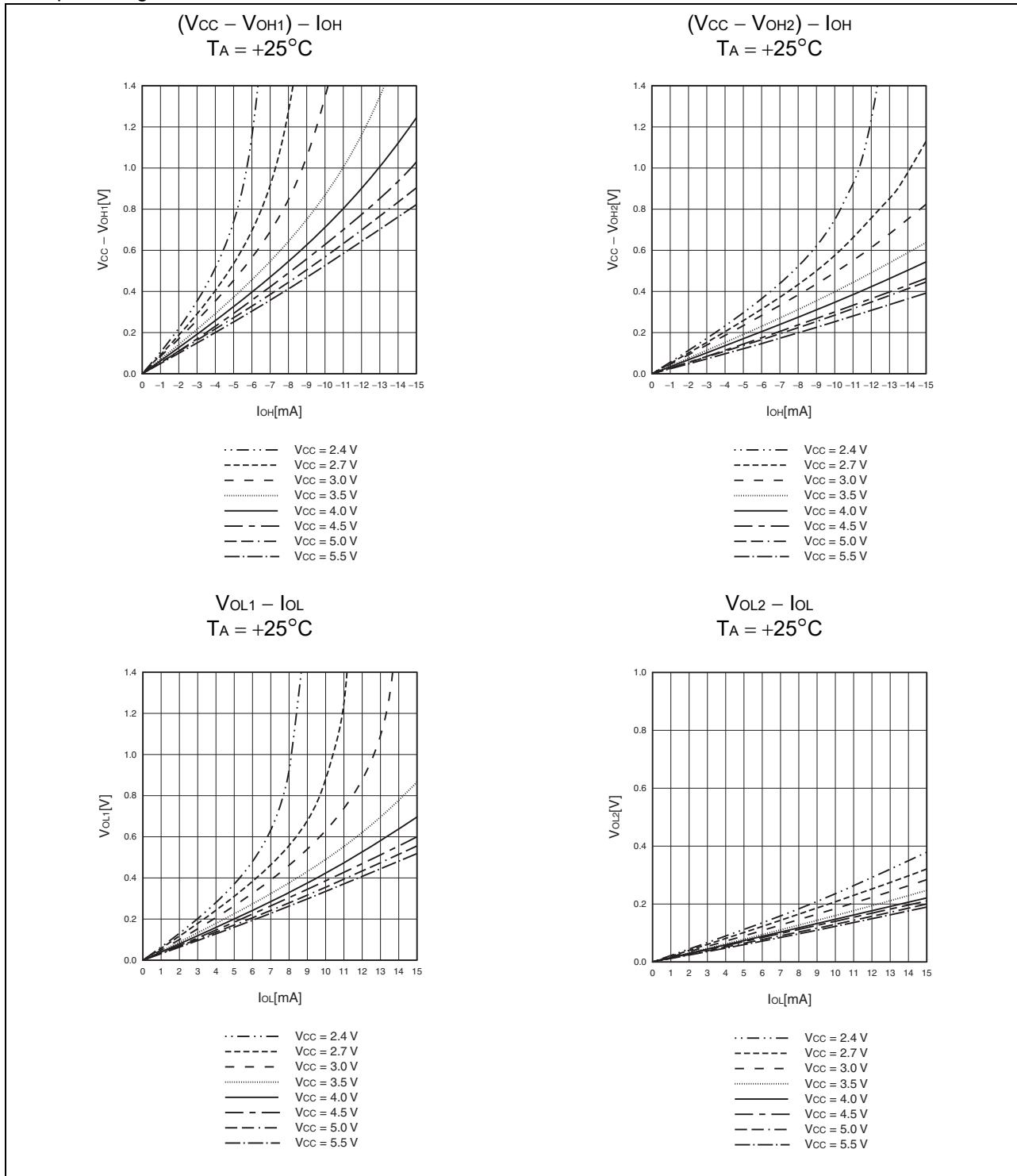

• Pull-up characteristics

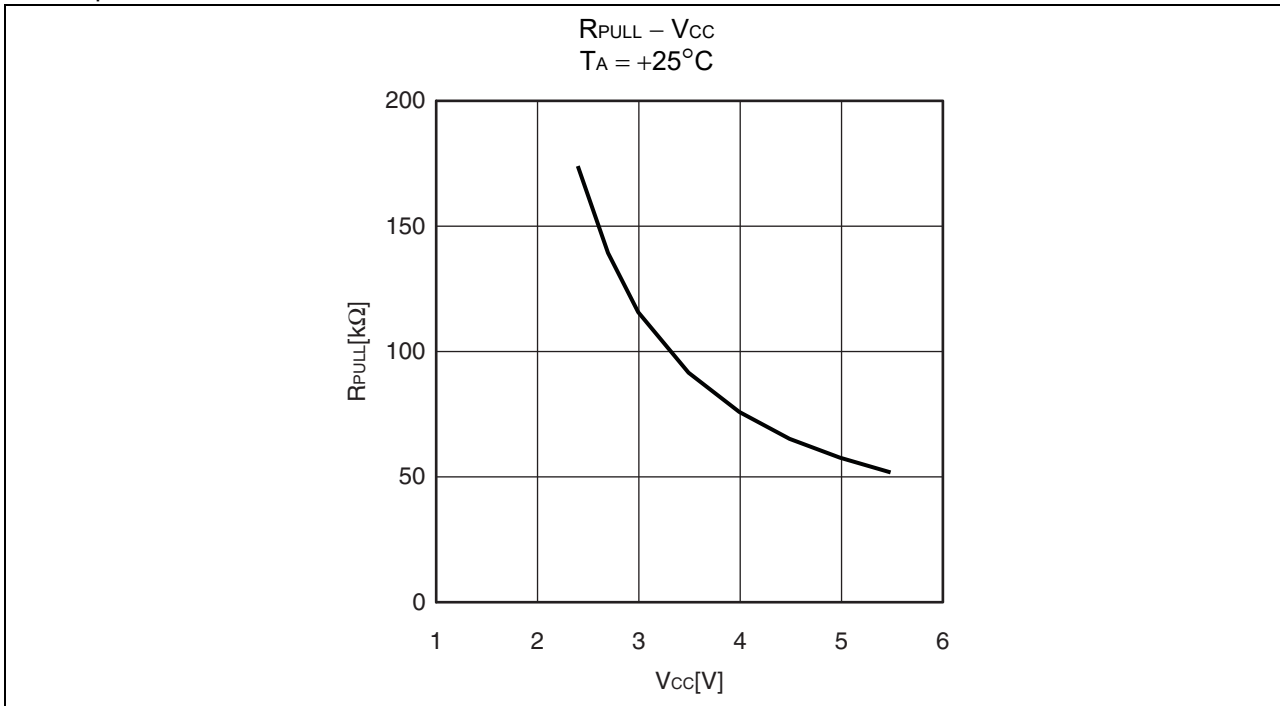

20. Mask Options

No.	Part number	CY95F632H CY95F633H CY95F634H CY95F636H	CY95F632K CY95F633K CY95F634K CY95F636K
	Selectable/Fixed	Fixed	
1	Low-voltage detection reset	Without low-voltage detection reset	With low-voltage detection reset
2	Reset	With dedicated reset input	Without dedicated reset input

21. Ordering Information

Part number	Package	Packing
CY95F632KPMC-G-UNE2 CY95F633KPMC-G-UNE2 CY95F634HPMC-G-UNE2 CY95F634KPMC-G-UNE2 CY95F636KPMC-G-UNE2	32-pin plastic LQFP (LQB032)	Tray
CY95F633HPMC-G-UNERE2		Reel

22. Package Dimension

Package Type	Package Code
LQFP 32	LQB032

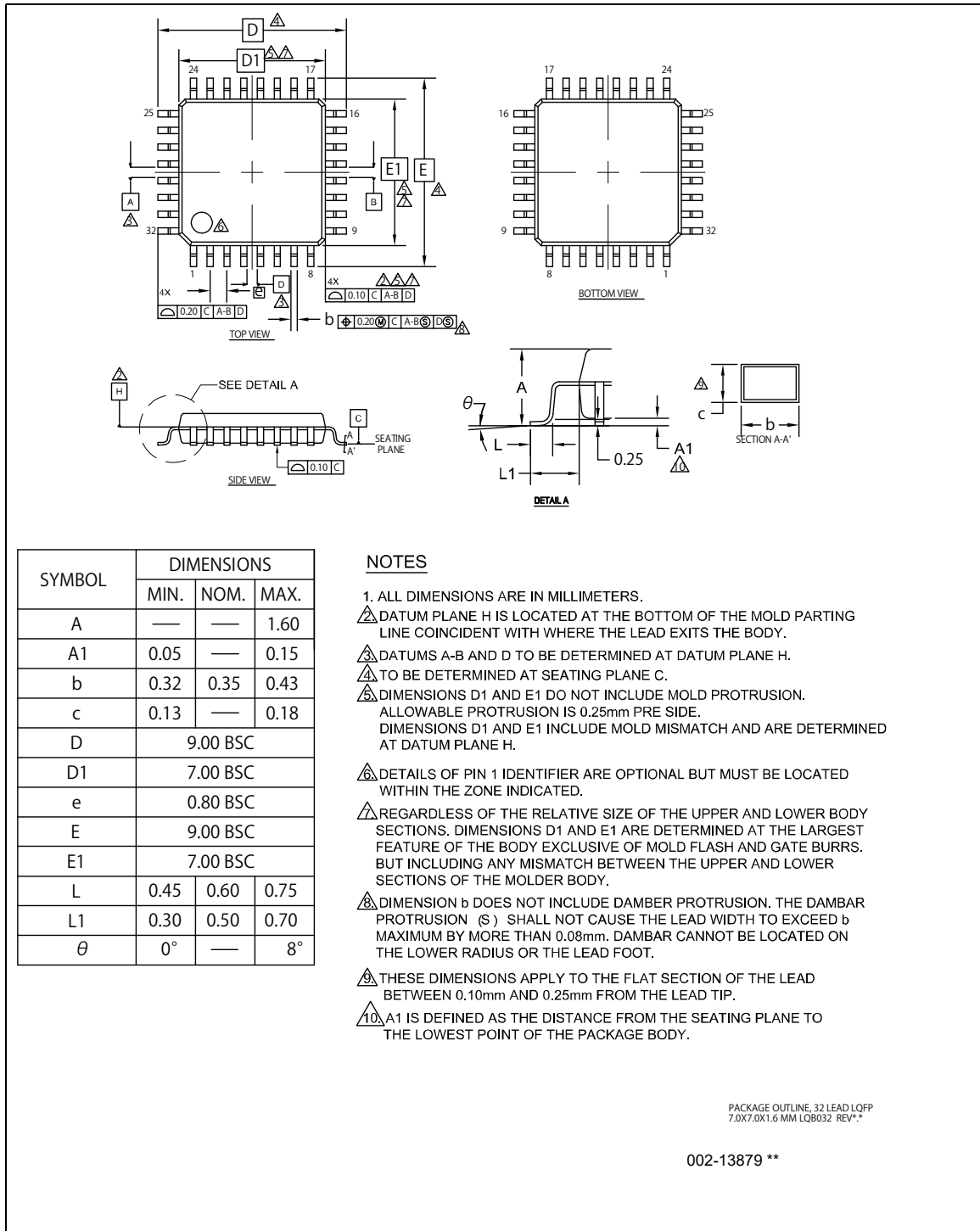

Package Type	Package Code
SDIP 32	PDS032

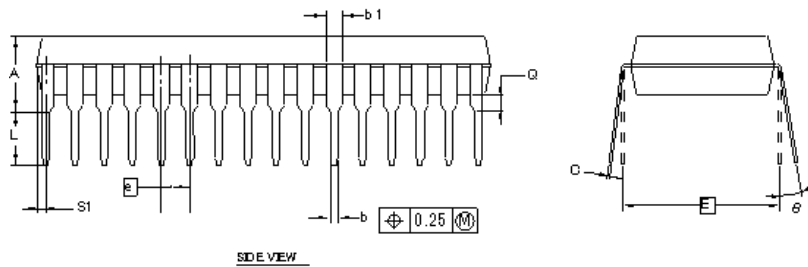
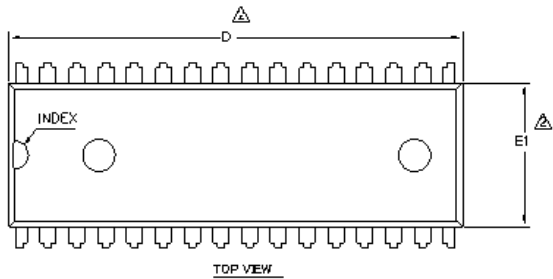

SYMBOL	DIMENSIONS		
	MIN.	NOM.	MAX.
A	4.50	4.70	5.40
L	3.00	3.30	3.50
D	27.70	28.00	28.20
E	10.16 BSC		
E1	8.64	8.89	9.14
θ	0°	—	15°
c	0.20	0.27	0.30
b	0.36	0.48	0.56
b1	0.82	1.02	1.32
e	1.778 BSC		
S1	—	—	1.27
Q	0.51	—	—

NOTES

1. ALL DIMENSIONS ARE IN MILLIMETER.
2. DIMENSIONS NOT INCLUDE RESIN REMAINING.
3. TERMINAL WIDTH AND TERMINAL THICKNESS INCLUDE PLATING THICKNESS.
4. JEDEC SPECIFICATION NO. REF : N/A

PACKAGE OUTLINE, 32 LEAD PDIP
28.00X8.89X4.19 NIM PDS032 REV**

002-16908 **

Package Type	Package Code
QFN 32	WNP032

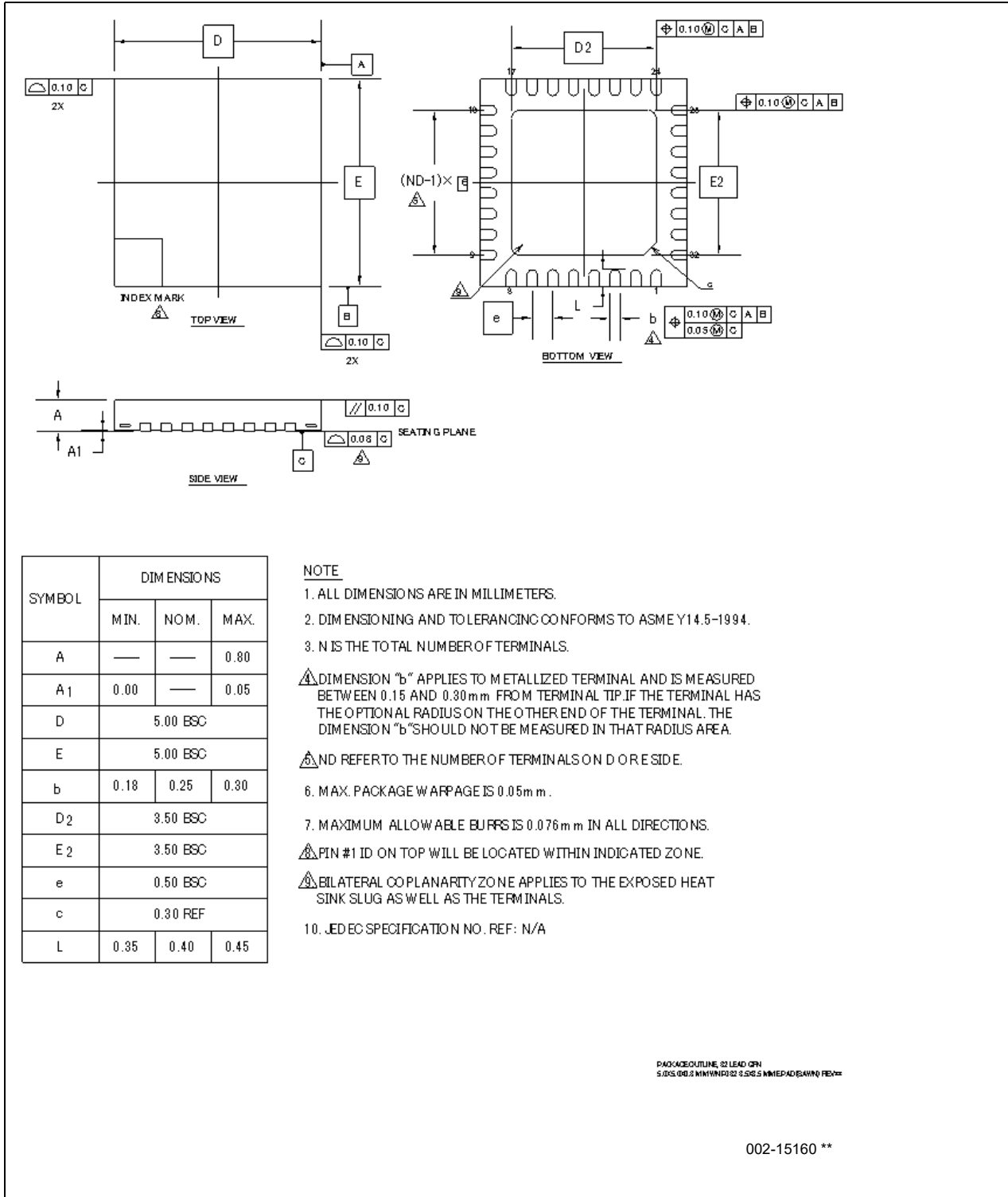

SYMBOL	DIMENSIONS		
	MIN.	NOM.	MAX.
A	—	—	0.80
A1	0.00	—	0.05
D	5.00 BSC		
E	5.00 BSC		
b	0.18	0.25	0.30
D2	3.50 BSC		
E2	3.50 BSC		
e	0.50 BSC		
c	0.30 REF		
L	0.35	0.40	0.45

NOTE

- ALL DIMENSIONS ARE IN MILLIMETERS.
- DIMENSIONING AND TOLERANCING CONFORMS TO ASME Y14.5-1994.
- N IS THE TOTAL NUMBER OF TERMINALS.
- △ DIMENSION "b" APPLIES TO METALLIZED TERMINAL AND IS MEASURED BETWEEN 0.15 AND 0.30 mm FROM TERMINAL TIP IF THE TERMINAL HAS THE OPTIONAL RADIUS ON THE OTHER END OF THE TERMINAL, THE DIMENSION "b" SHOULD NOT BE MEASURED IN THAT RADIUS AREA.
- △ ND REFERS TO THE NUMBER OF TERMINALS ON D OR E SIDE.
- MAX. PACKAGE WARPAGE IS 0.05 mm.
- MAXIMUM ALLOWABLE BURRS IS 0.076 mm IN ALL DIRECTIONS.
- △ PIN #1 ID ON TOP WILL BE LOCATED WITHIN INDICATED ZONE.
- △ BILATERAL COPLANARITY ZONE APPLIES TO THE EXPOSED HEAT SINK SLUG AS WELL AS THE TERMINALS.
- JEDEC SPECIFICATION NO. REF: N/A

PACKAGE OUTLINE, 32 LEAD QFN
5.00x5.00x0.55 MM (WNP032) 3.50x3.50x0.55 MM (EAD032WNP) REF: 002-15160 **

002-15160 **

23. Major Changes In This Edition

Spanion Publication Number: DS702-00009

Page	Section	Details
22	<p>■ PIN CONNECTION</p> <ul style="list-style-type: none"> • C pin 	<p>Corrected the following statement. The bypass capacitor for the V_{CC} pin must have a capacitance larger than C_s. → The decoupling capacitor for the V_{CC} pin must have a capacitance equal to or larger than the capacitance of C_s.</p>
66	<p>■ ELECTRICAL CHARACTERISTICS</p> <p>2. Recommended Operating Conditions</p>	<p>Corrected the following statement in remark *2. The bypass capacitor for the V_{CC} pin must have a capacitance larger than C_s. → The decoupling capacitor for the V_{CC} pin must have a capacitance equal to or larger than the capacitance of C_s.</p>
71	<p>4. AC Characteristics</p> <p>(1) Clock Timing</p>	<p>Corrected the pin names of the parameter “Input clock rising time and falling time”.</p> <p>X0 → X0, X0A X0, X1 → X0, X1, X0A, X1A</p>

NOTE: Please see “Document History” about later revised information.

Document History Page

Document Title: CY95630H Series, New 8FX 8-bit Microcontrollers Document Number: 002-04627			
Revision	ECN	Submission Date	Description of Change
**	–	06/07/2013	Migrated to Cypress and assigned document number 002-04627. No change to document contents or format.
*A	5193921	03/29/2016	Updated Ordering Information: Updated part numbers. Updated to Cypress template.
*B	5443796	02/06/2017	Replaced “FPT-32P-M30” with “LQB032” in all instances across the document. Replaced “LCC-32P-M19” with “WNP032” in all instances across the document. Replaced “DIP-32P-M06” with “PDS032” in all instances across the document. Updated Ordering Information: Updated part numbers.
*C	5746267	05/23/2017	Updated Cypress Logo and Copyright.
*D	5895915	09/27/2017	Updated Ordering Information: Updated part numbers. Added a column “Packing” and added details in that column.
*E	6599271	06/19/2019	Updated Ordering Information: Updated part numbers. Updated to new template.
*F	6730588	11/13/2019	Updated series name and part number from prefix MB to prefix CY.
*G	6748761	12/10/2019	Added ordering part numbers: CY95F632KPMC-G-UNE2 CY95F633KPMC-G-UNE2 CY95F634KPMC-G-UNE2 CY95F636KPMC-G-UNE2

Sales, Solutions, and Legal Information

Worldwide Sales and Design Support

Cypress maintains a worldwide network of offices, solution centers, manufacturer's representatives, and distributors. To find the office closest to you, visit us at [Cypress Locations](#).

Products

Arm® Cortex® Microcontrollers	cypress.com/arm
Automotive	cypress.com/automotive
Clocks & Buffers	cypress.com/clocks
Interface	cypress.com/interface
Internet of Things	cypress.com/iot
Memory	cypress.com/memory
Microcontrollers	cypress.com/mcu
PSoC	cypress.com/psoc
Power Management ICs	cypress.com/pmic
Touch Sensing	cypress.com/touch
USB Controllers	cypress.com/usb
Wireless Connectivity	cypress.com/wireless

PSoC® Solutions

[PSoC 1](#) | [PSoC 3](#) | [PSoC 4](#) | [PSoC 5LP](#) | [PSoC 6 MCU](#)

Cypress Developer Community

[Community](#) | [Projects](#) | [Video](#) | [Blogs](#) | [Training](#) | [Components](#)

Technical Support

cypress.com/support

© Cypress Semiconductor Corporation, 2011–2019. This document is the property of Cypress Semiconductor Corporation and its subsidiaries ("Cypress"). This document, including any software or firmware included or referenced in this document ("Software"), is owned by Cypress under the intellectual property laws and treaties of the United States and other countries worldwide. Cypress reserves all rights under such laws and treaties and does not, except as specifically stated in this paragraph, grant any license under its patents, copyrights, trademarks, or other intellectual property rights. If the Software is not accompanied by a license agreement and you do not otherwise have a written agreement with Cypress governing the use of the Software, then Cypress hereby grants you a personal, non-exclusive, nontransferable license (without the right to sublicense) (1) under its copyright rights in the Software (a) for Software provided in source code form, to modify and reproduce the Software solely for use with Cypress hardware products, only internally within your organization, and (b) to distribute the Software in binary code form externally to end users (either directly or indirectly through resellers and distributors), solely for use on Cypress hardware product units, and (2) under those claims of Cypress's patents that are infringed by the Software (as provided by Cypress, unmodified) to make, use, distribute, and import the Software solely for use with Cypress hardware products. Any other use, reproduction, modification, translation, or compilation of the Software is prohibited.

TO THE EXTENT PERMITTED BY APPLICABLE LAW, CYPRESS MAKES NO WARRANTY OF ANY KIND, EXPRESS OR IMPLIED, WITH REGARD TO THIS DOCUMENT OR ANY SOFTWARE OR ACCOMPANYING HARDWARE, INCLUDING, BUT NOT LIMITED TO, THE IMPLIED WARRANTIES OF MERCHANTABILITY AND FITNESS FOR A PARTICULAR PURPOSE. No computing device can be absolutely secure. Therefore, despite security measures implemented in Cypress hardware or software products, Cypress shall have no liability arising out of any security breach, such as unauthorized access to or use of a Cypress product. CYPRESS DOES NOT REPRESENT, WARRANT, OR GUARANTEE THAT CYPRESS PRODUCTS, OR SYSTEMS CREATED USING CYPRESS PRODUCTS, WILL BE FREE FROM CORRUPTION, ATTACK, VIRUSES, INTERFERENCE, HACKING, DATA LOSS OR THEFT, OR OTHER SECURITY INTRUSION (collectively, "Security Breach"). Cypress disclaims any liability relating to any Security Breach, and you shall and hereby do release Cypress from any claim, damage, or other liability arising from any Security Breach. In addition, the products described in these materials may contain design defects or errors known as errata which may cause the product to deviate from published specifications. To the extent permitted by applicable law, Cypress reserves the right to make changes to this document without further notice. Cypress does not assume any liability arising out of the application or use of any product or circuit described in this document. Any information provided in this document, including any sample design information or programming code, is provided only for reference purposes. It is the responsibility of the user of this document to properly design, program, and test the functionality and safety of any application made of this information and any resulting product. "High-Risk Device" means any device or system whose failure could cause personal injury, death, or property damage. Examples of High-Risk Devices are weapons, nuclear installations, surgical implants, and other medical devices. "Critical Component" means any component of a High-Risk Device whose failure to perform can be reasonably expected to cause, directly or indirectly, the failure of the High-Risk Device, or to affect its safety or effectiveness. Cypress is not liable, in whole or in part, and you shall and hereby do release Cypress from any claim, damage, or other liability arising from any use of a Cypress product as a Critical Component in a High-Risk Device. You shall indemnify and hold Cypress, its directors, officers, employees, agents, affiliates, distributors, and assigns harmless from and against all claims, costs, damages, and expenses, arising out of any claim, including claims for product liability, personal injury or death, or property damage arising from any use of a Cypress product as a Critical Component in a High-Risk Device. Cypress products are not intended or authorized for use as a Critical Component in any High-Risk Device except to the limited extent that (i) Cypress's published data sheet for the product explicitly states Cypress has qualified the product for use in a specific High-Risk Device, or (ii) Cypress has given you advance written authorization to use the product as a Critical Component in the specific High-Risk Device and you have signed a separate indemnification agreement.

Cypress, the Cypress logo, Spansion, the Spansion logo, and combinations thereof, WICED, PSoC, CapSense, EZ-USB, F-RAM, and Traveo are trademarks or registered trademarks of Cypress in the United States and other countries. For a more complete list of Cypress trademarks, visit cypress.com. Other names and brands may be claimed as property of their respective owners.

Mouser Electronics

Authorized Distributor

Click to View Pricing, Inventory, Delivery & Lifecycle Information:

Cypress Semiconductor:

[CY95F636KPMC-G-UNE2](#) [CY95F633HPMC-G-UNERE2](#) [CY95F633KPMC-G-UNE2](#) [CY95F632KPMC-G-UNE2](#)
[CY95F634KPMC-G-UNE2](#)